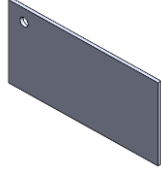

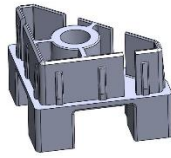

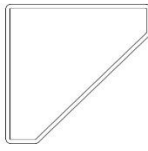

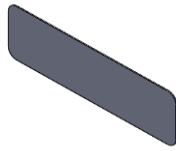
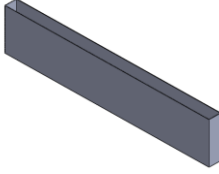


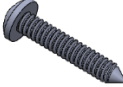
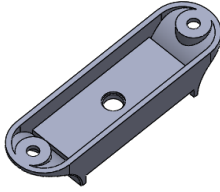


Components Used in Collaborate Desking System

SL. No.	Components name	Images
1	Table Top	
2	Collaborate leg tube	
3	Collaborate leg shoe	
4	Collaborate leg leveler	
5	Collaborate tube Section	
6	Centre screen holder	
7	Screen	

8	MS Raceway	
9	Vetical Wire entry	
10	M6x 20 Allen Flange Head	
11	10X19 Pan head Screw	
12	50mm Spacer	

TOOLS USED IN INSTALLATION

Tool No. Name of the tool

Image

1 Cordless Machine



2 Cordless Machine



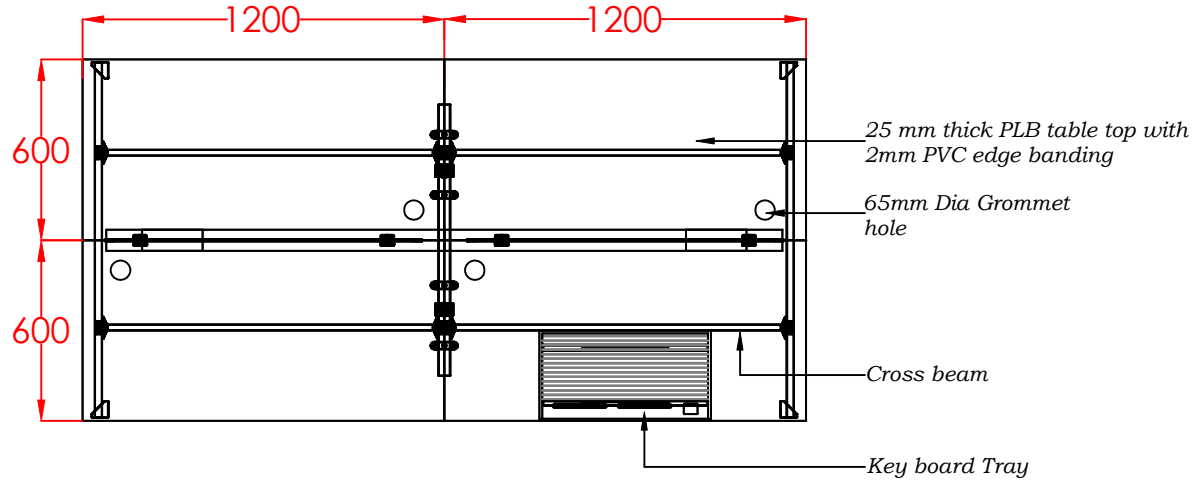
3 Rubber Mallet



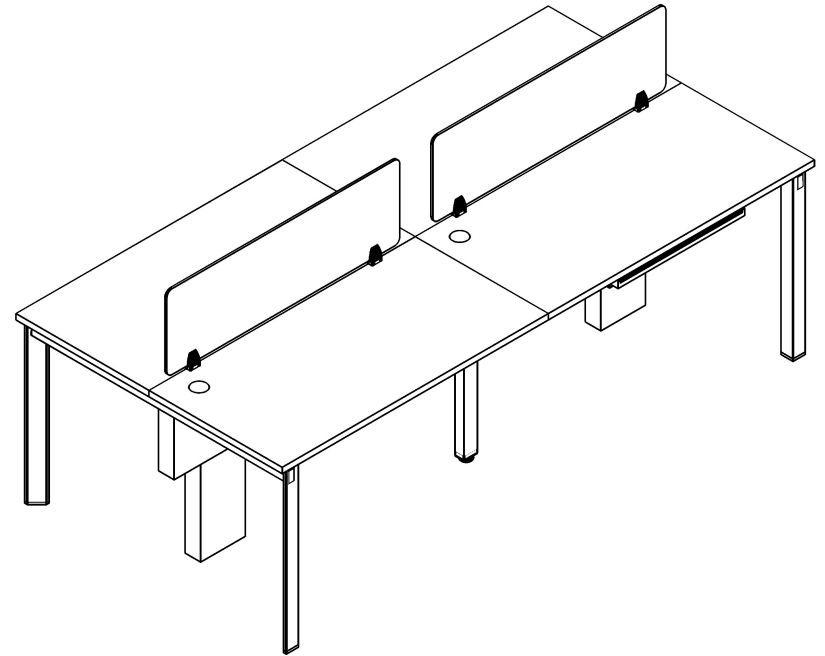
COLLABORATE SYSTEM - FULLY ASSEMBLED

Featherlite[®]

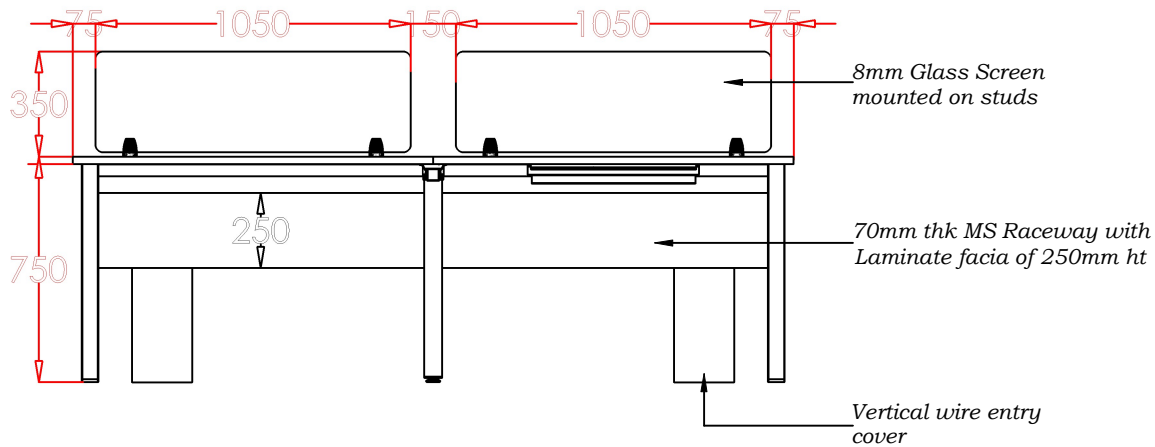
TOP VIEW



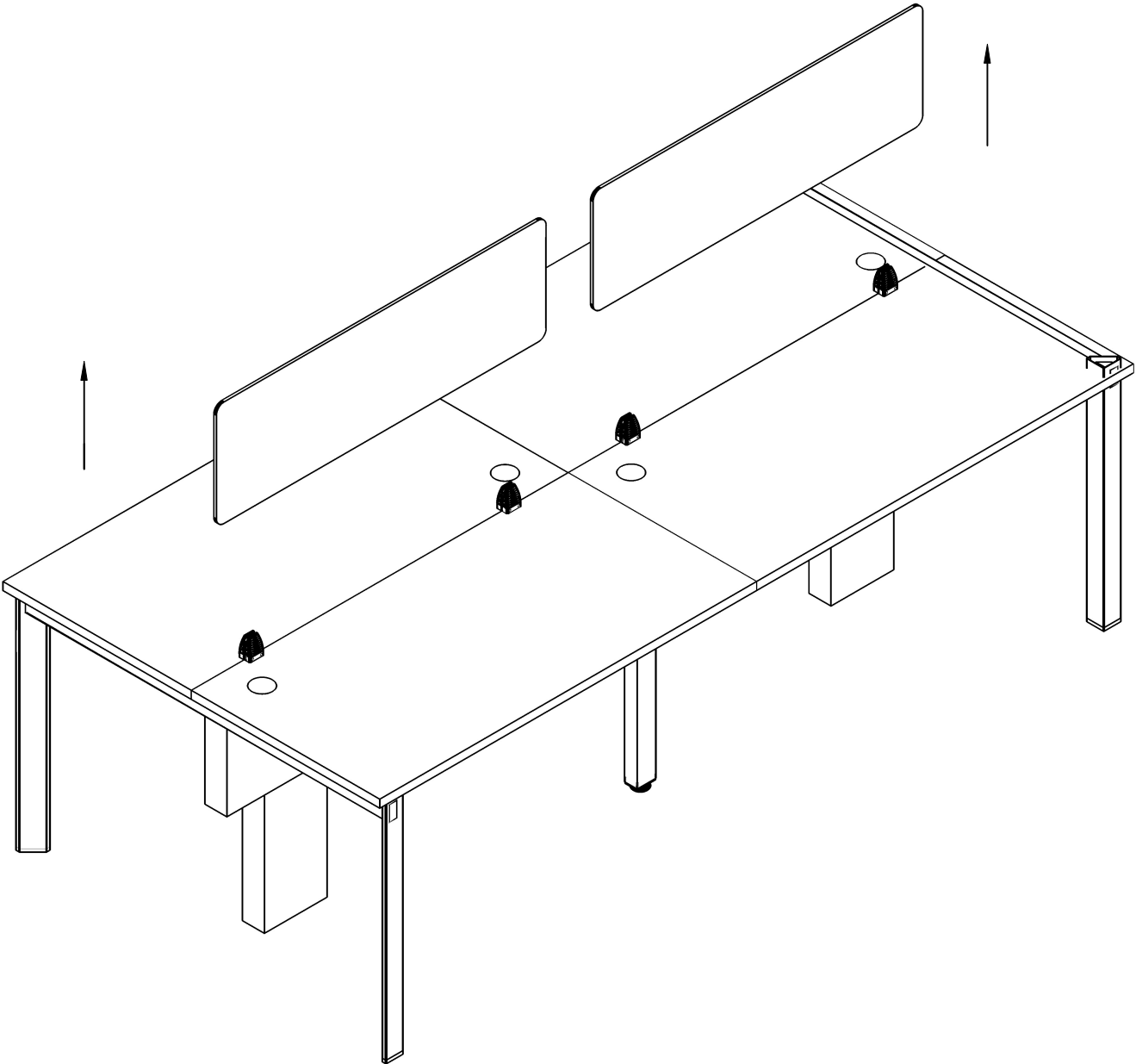
ISOMETRIC VIEW



FRONT VIEW

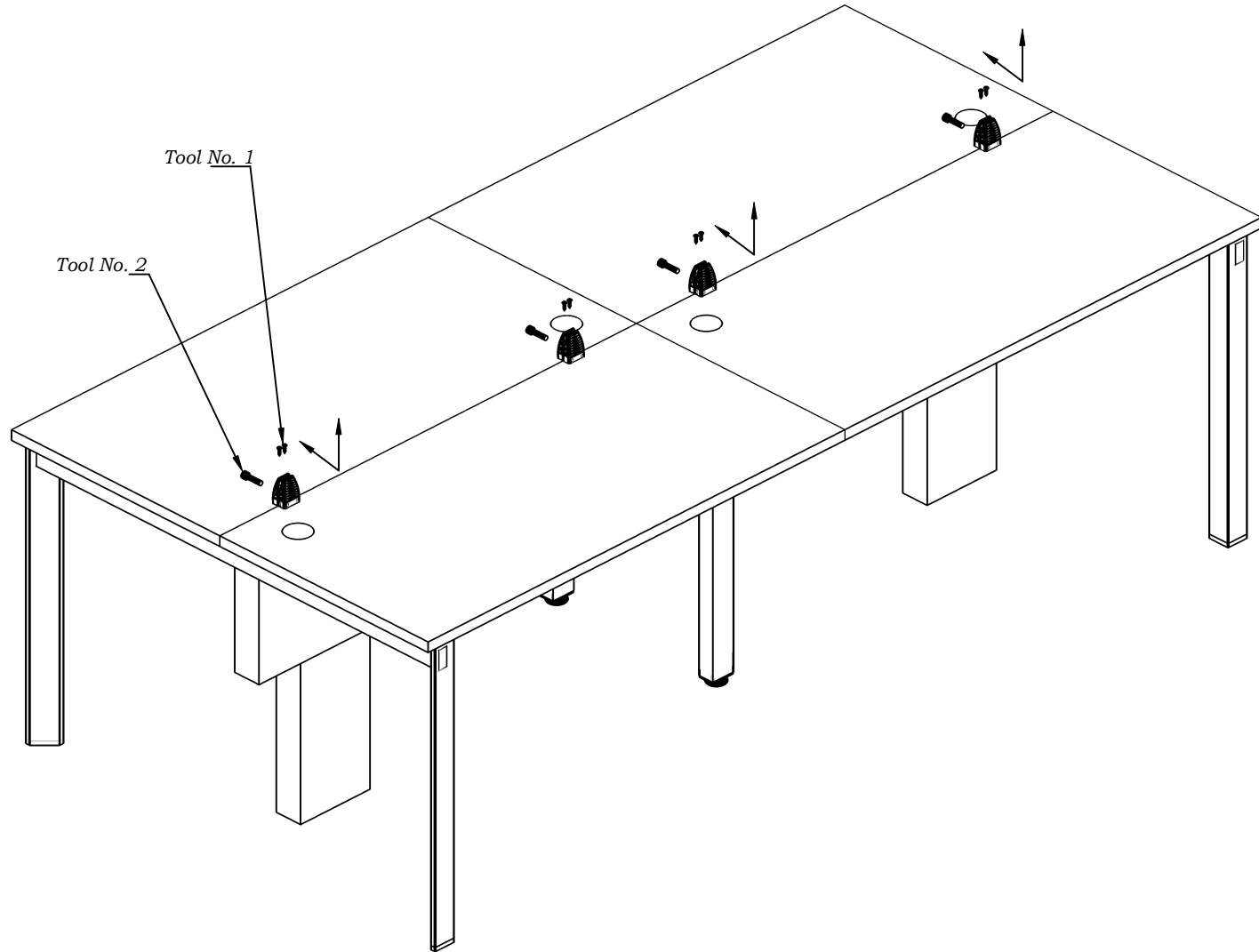


STEP 1 : SCREEN REMOVAL



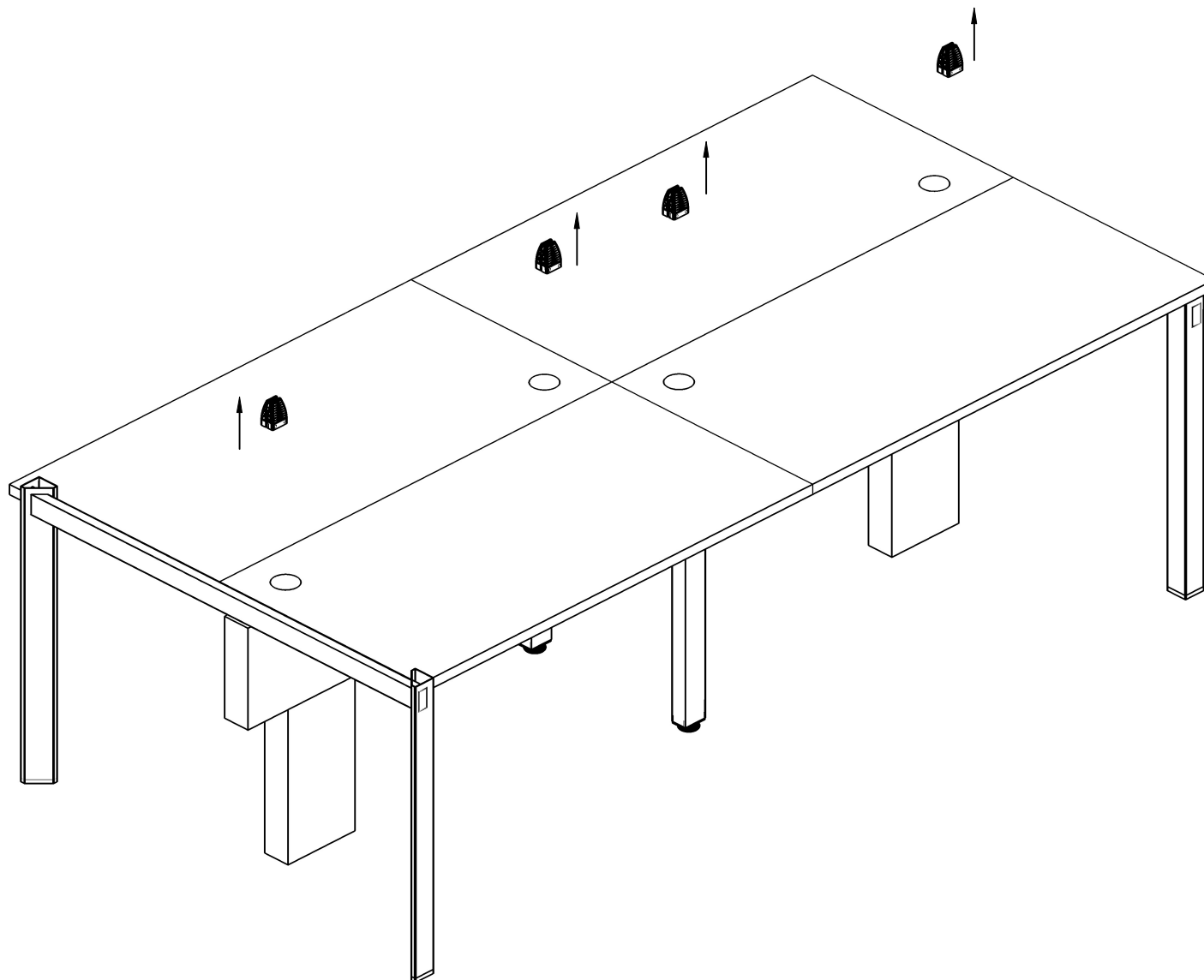
STEP 2 : SCREEN HOLDER SCREWS REMOVE

Featherlite[®]



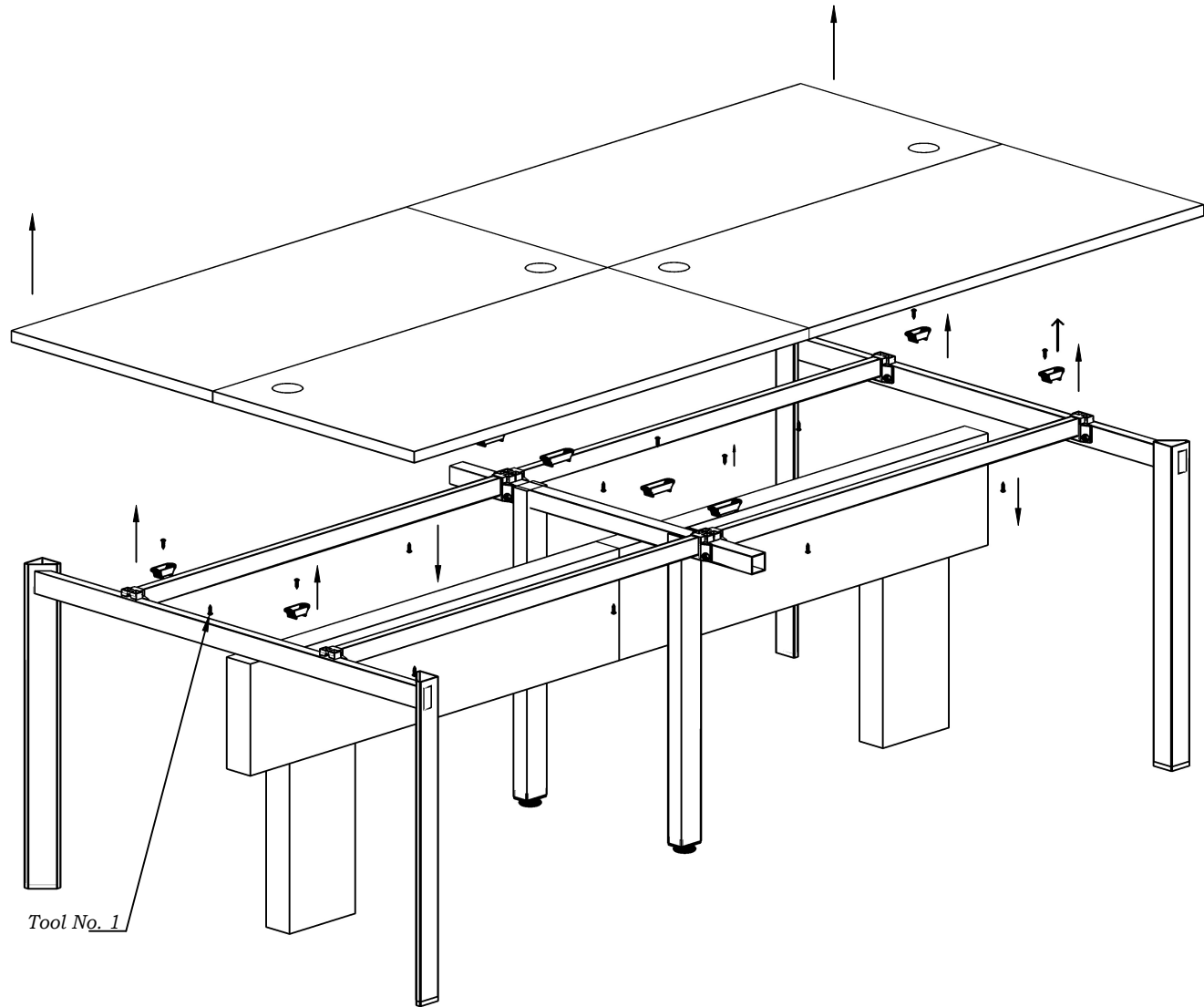
STEP 3 : SCREEN HOLDER REMOVE

Featherlite[®]



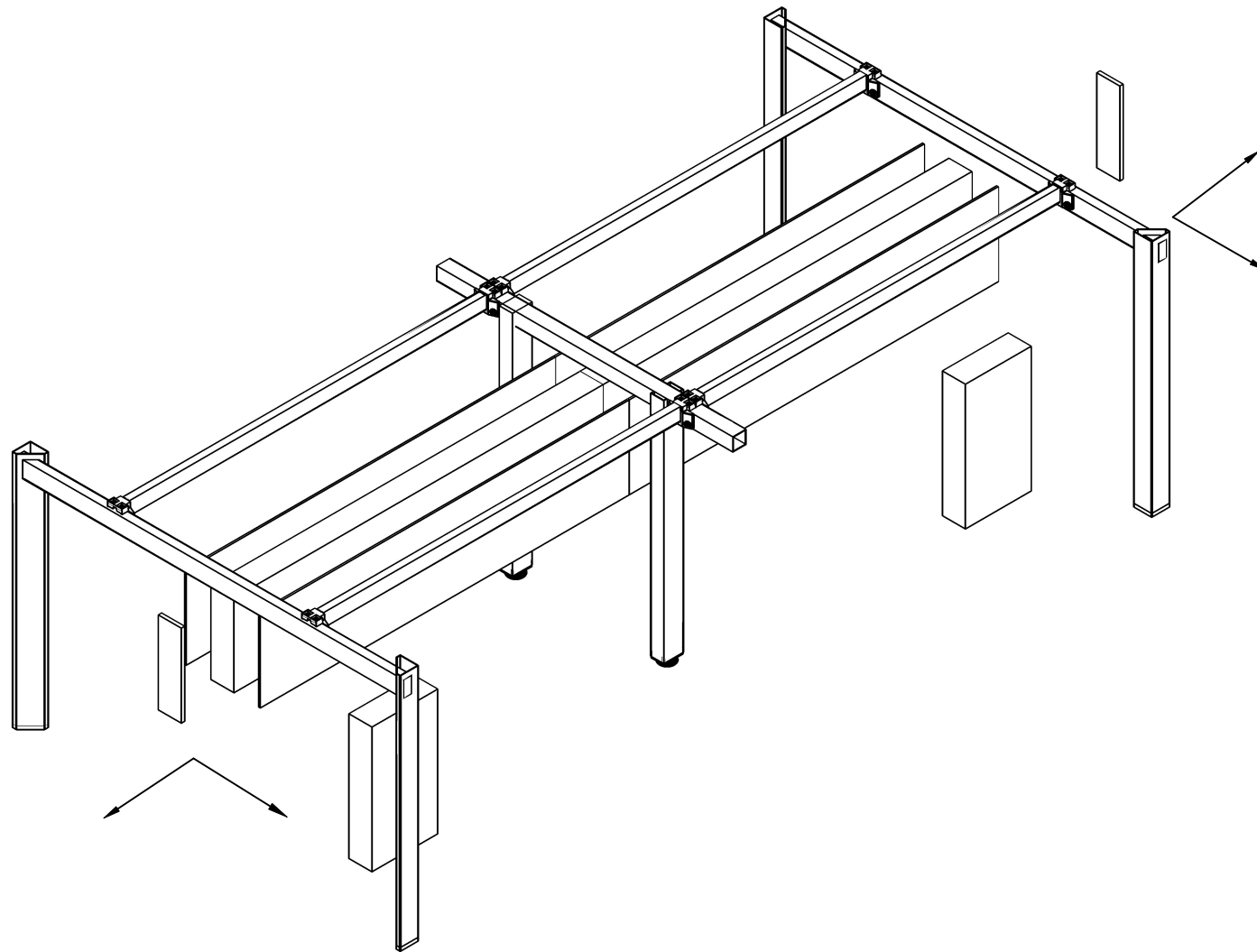
STEP 4 : TABLE TOP & SPACER REMOVAL

Featherlite[®]



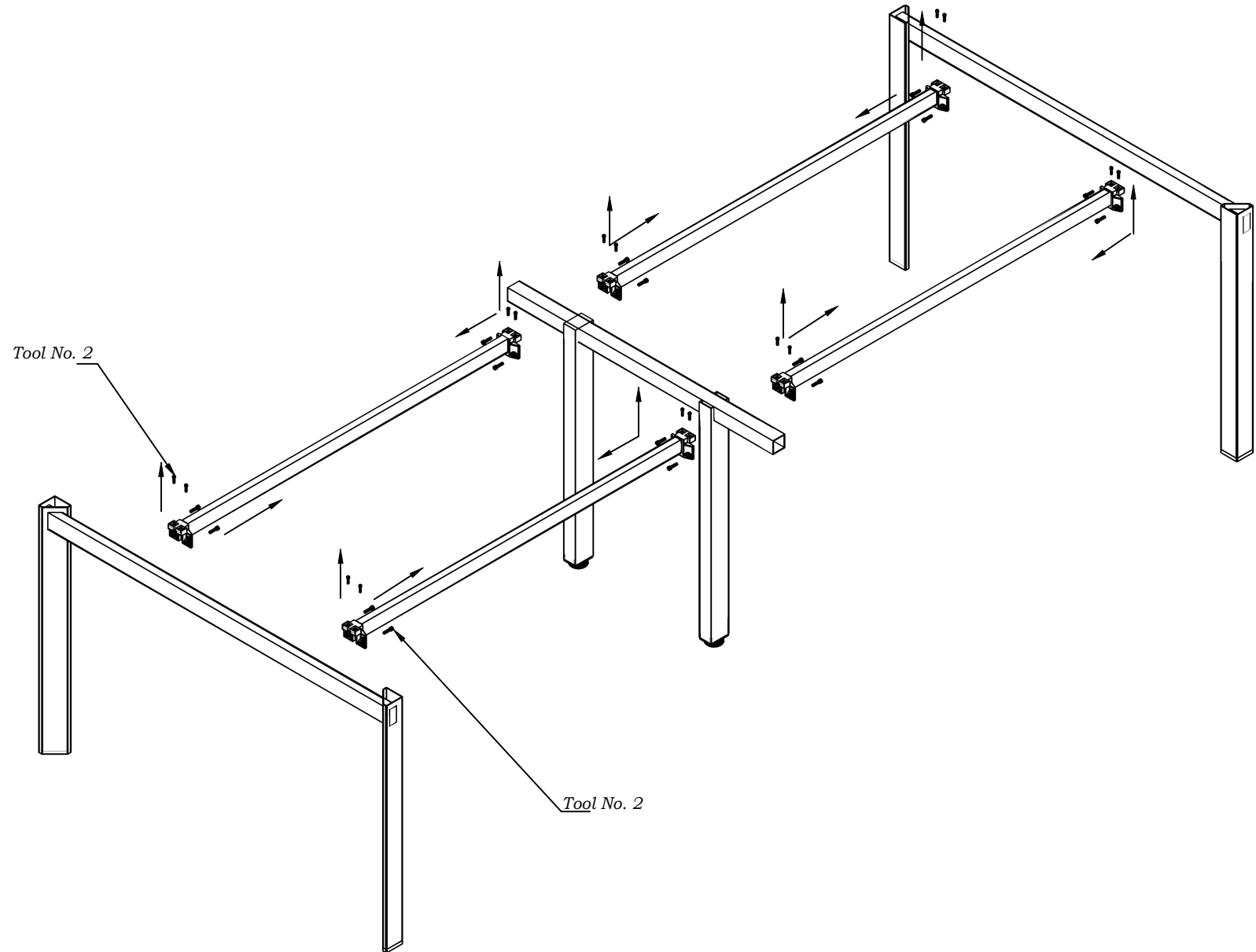
STEP 5 : RACEWAY/SIDE TRIM REMOVAL

Featherlite[®]



STEP 6 : CROSS BEAM & LEG ASSEMBLY REMOVAL

Featherlite[®]



Dis assembly instrcutions.

Disassembly Sequence, Time Schedule and Tools Requirement for COLLABORATE Desking System.

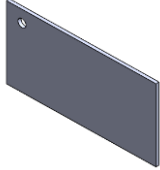
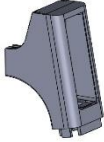
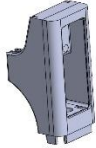

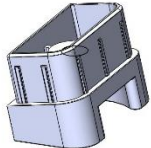
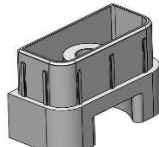


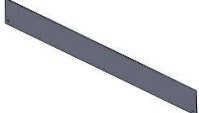
Table 1



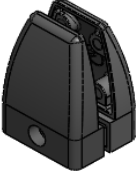
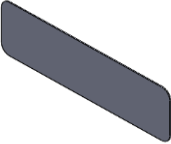
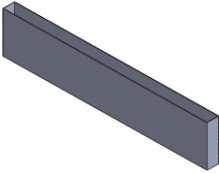
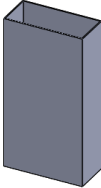



<u>Sl.No</u>	<u>Activity</u>	<u>Time in min</u>	<u>Tools required</u>
1.	Disconnect sockets/switches and take out the cables.	4	Cordless Machine
2.	Remove the screens	3	Cordless Machine
3.	Remove Table Top	3	Cordless Machine
4.	Remove race way covers	2	Manual
5.	Remove the vertical wire management raceway.	3	Cordless Machine
6.	Remove Raceway frames.	3	Cordless Machine
7.	Remove cross beams	3	Allen Keys.
8.	Remove spacers.	2	Cordless Machine
9.	Remove leg supports.	2	Manual
10.	Remove accessories.	3	Cordless Machine
11.	Pack all components	4	Manual

Total time per work station- 32 Mins.

The timings are based on a cluster of 4 work stations. The dismantling team consists of two persons. For dismantling more number of work stations, larger team can be used and the activity can be telescoped.

Components Used in Colours Desking System

SL. No.	Components name	Images
1	Table Top	
2	Colours 10 deg connector	
3	Colours 90 deg connector	
4	Colours coonector cap	
5	10 deg leg shoe	
6	90 deg leg shoe	
7	Colours leveler	
8	Colours leg band strip holding extrusion	
9	Colours leg band strip	

10	Colours Leg	
11	Colours Leg beam tube Section	
12	Centre screen holder	
13	Screen	
14	MS Raceway	
15	Vetical Wire entry	
16	M6x 20 Allen Flange Head	
17	10X19 Pan head Screw	
18	50mm Spacer	

TOOLS USED IN INSTALLATION

Tool No. Name of the tool

Image

1 Cordless Machine



2 Cordless Machine



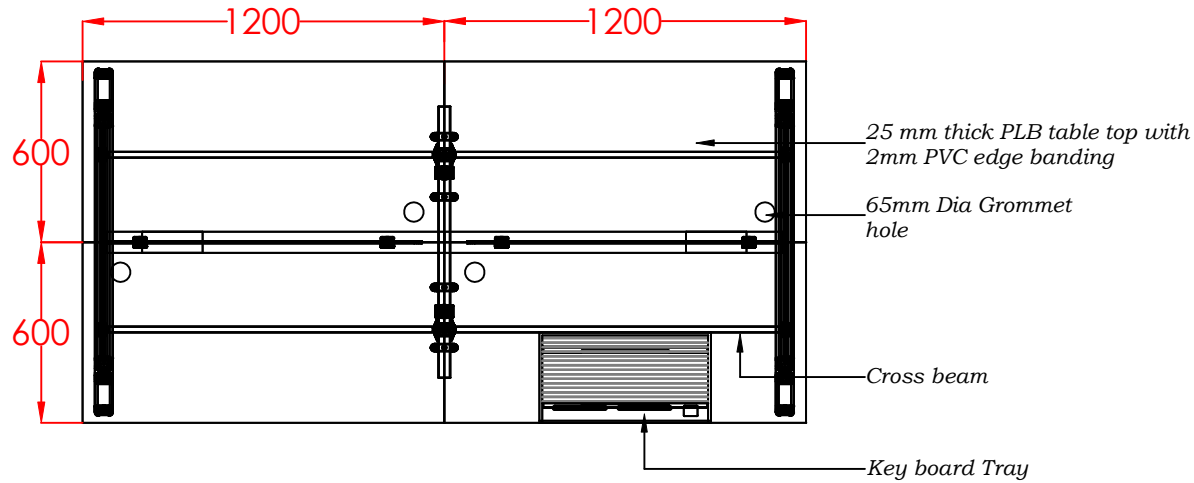
3 Rubber Mallet



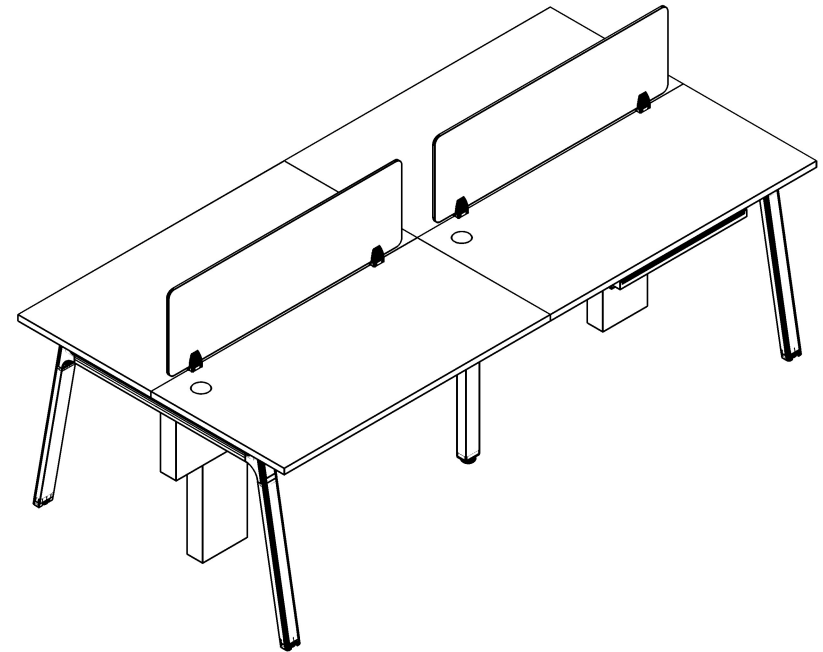
COLOURS SYSTEM - FULLY ASSEMBLED

Featherlite®

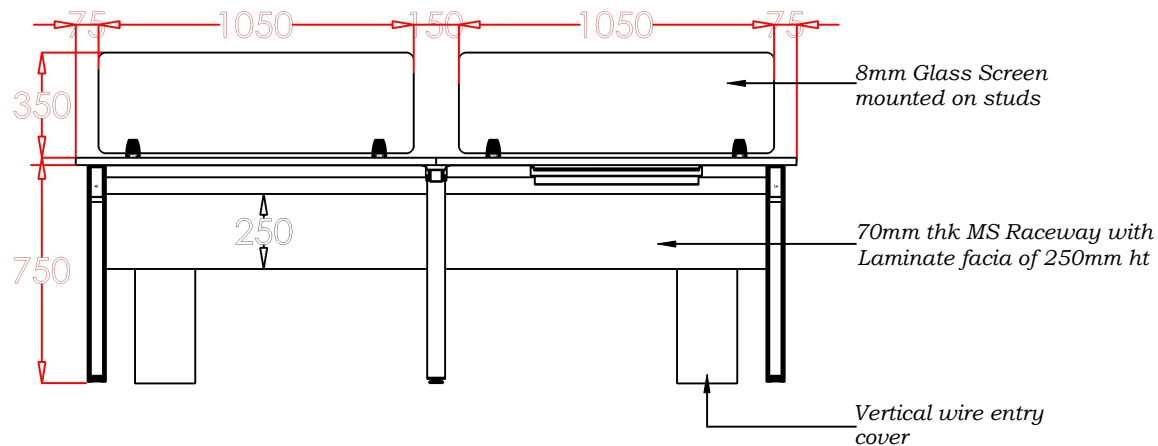
TOP VIEW



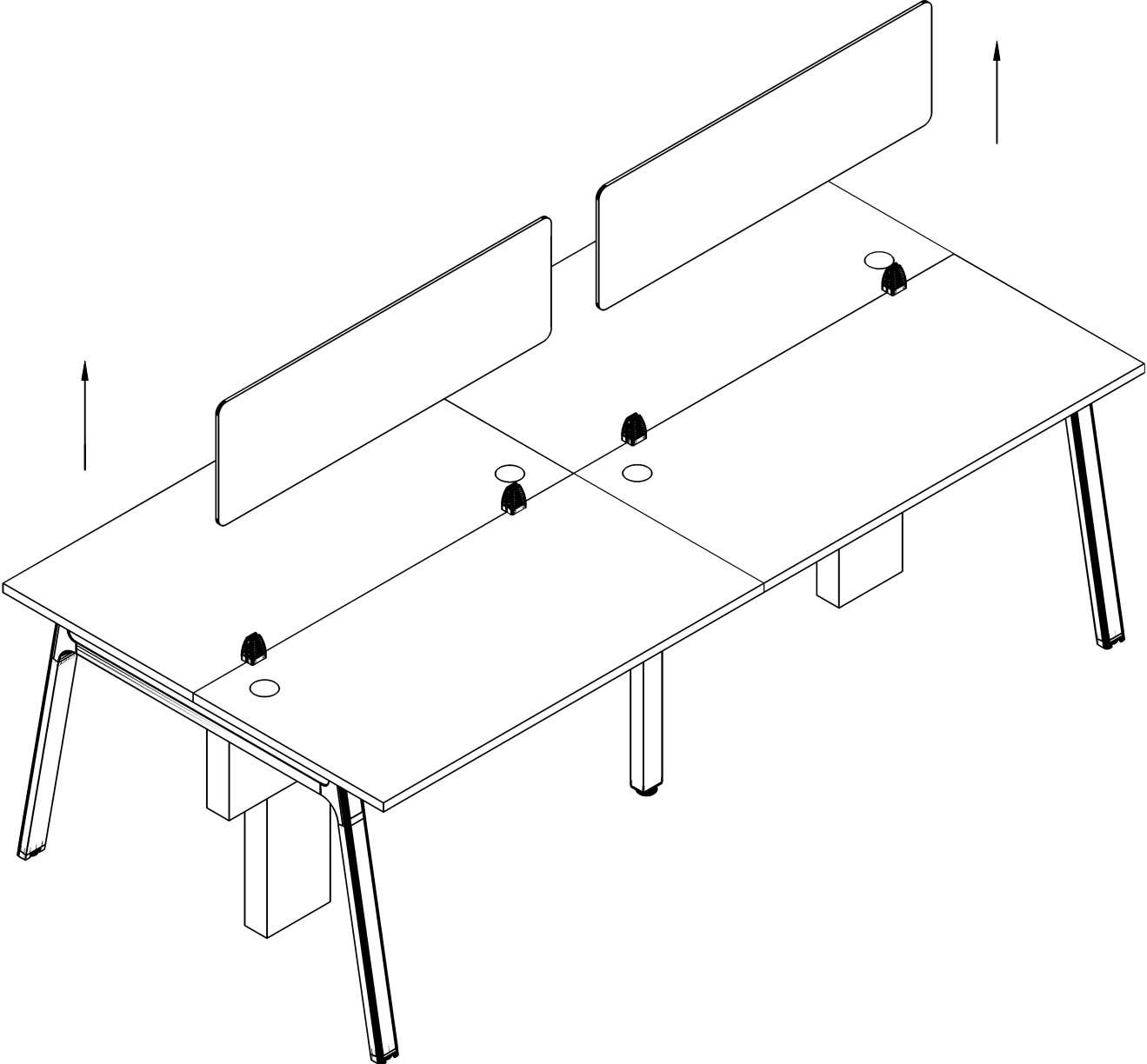
ISOMETRIC VIEW



FRONT VIEW

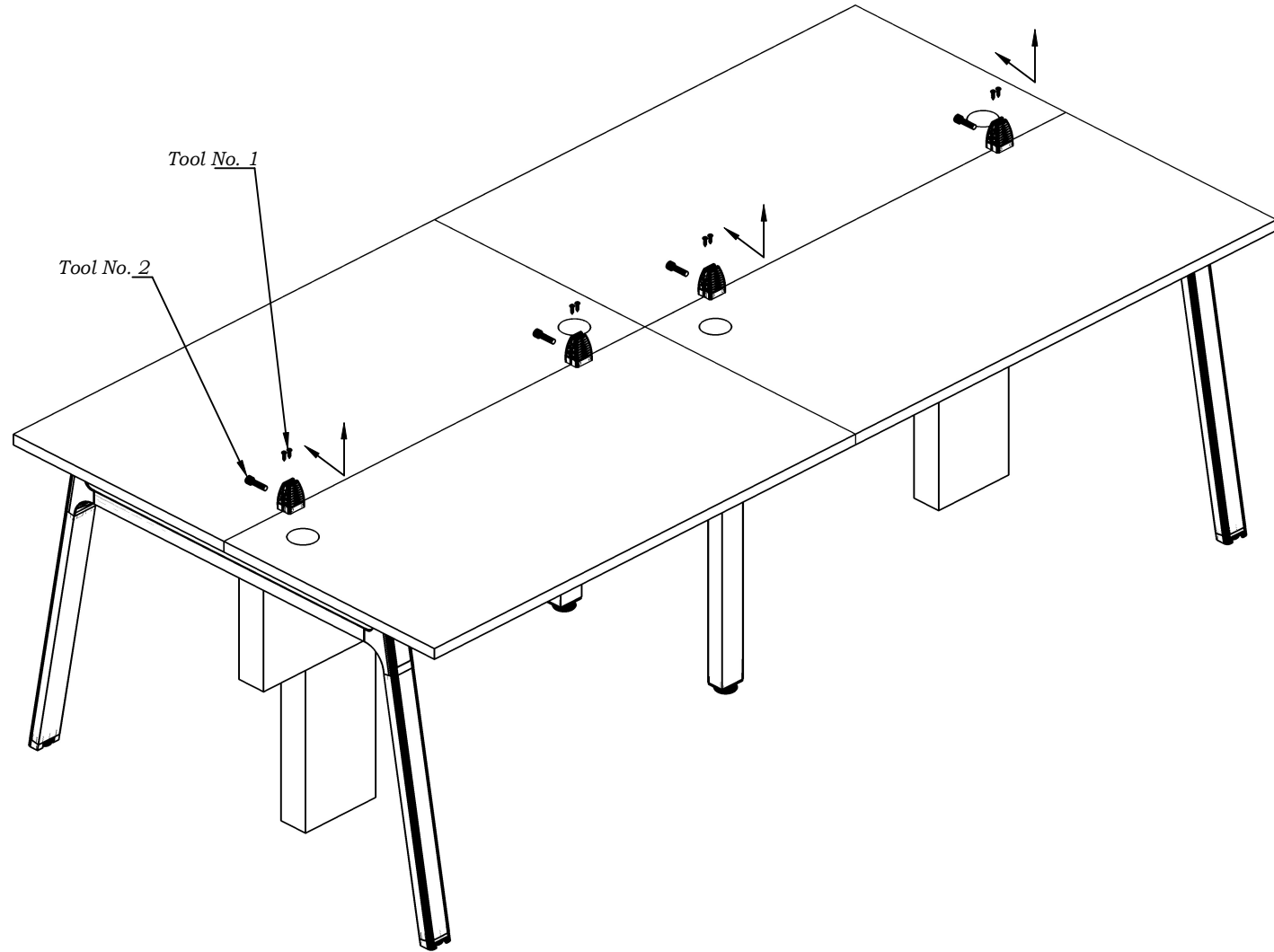


STEP 1 : SCREEN REMOVAL



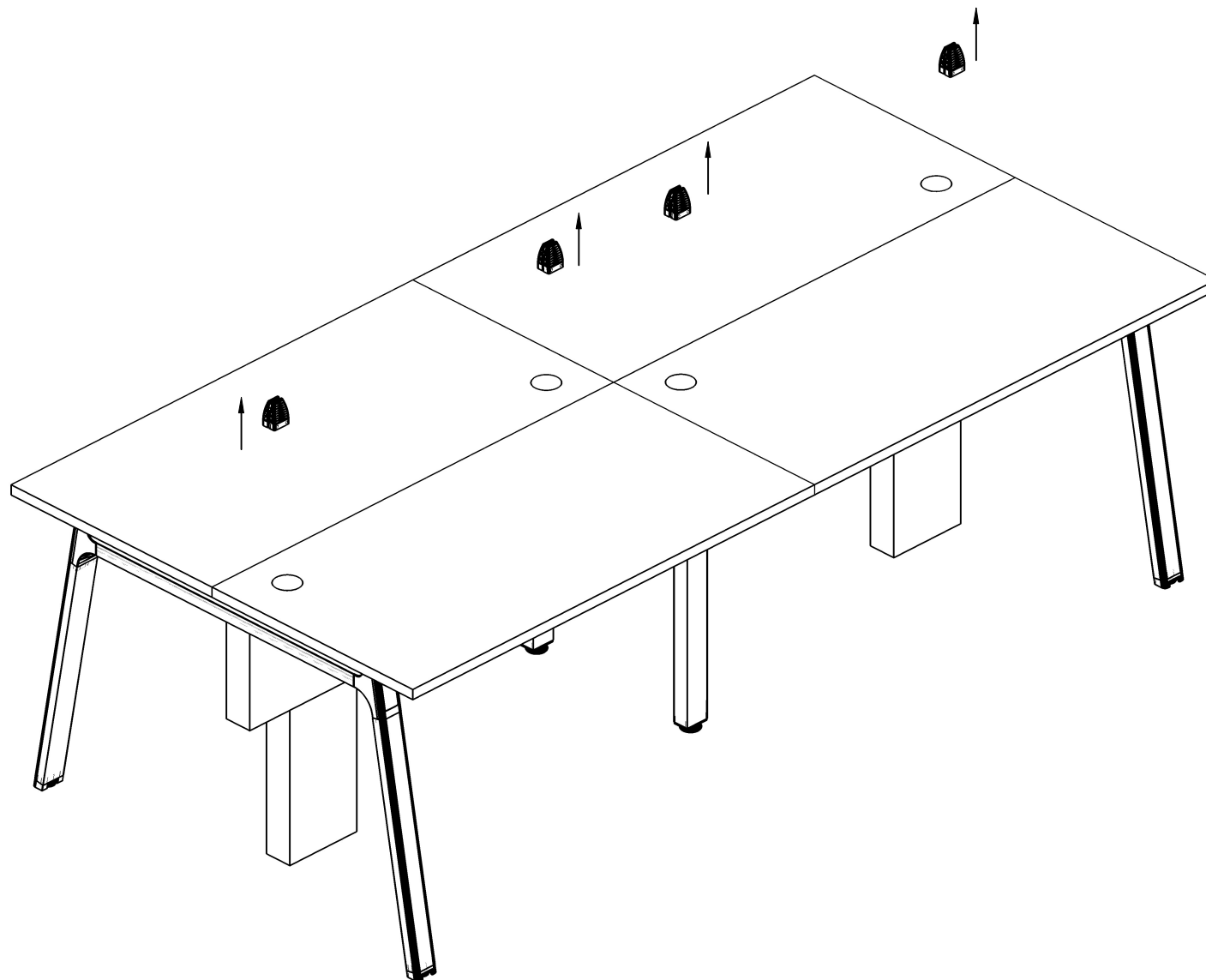
STEP 2 : SCREEN HOLDER SCREWS REMOVE

Featherlite[®]



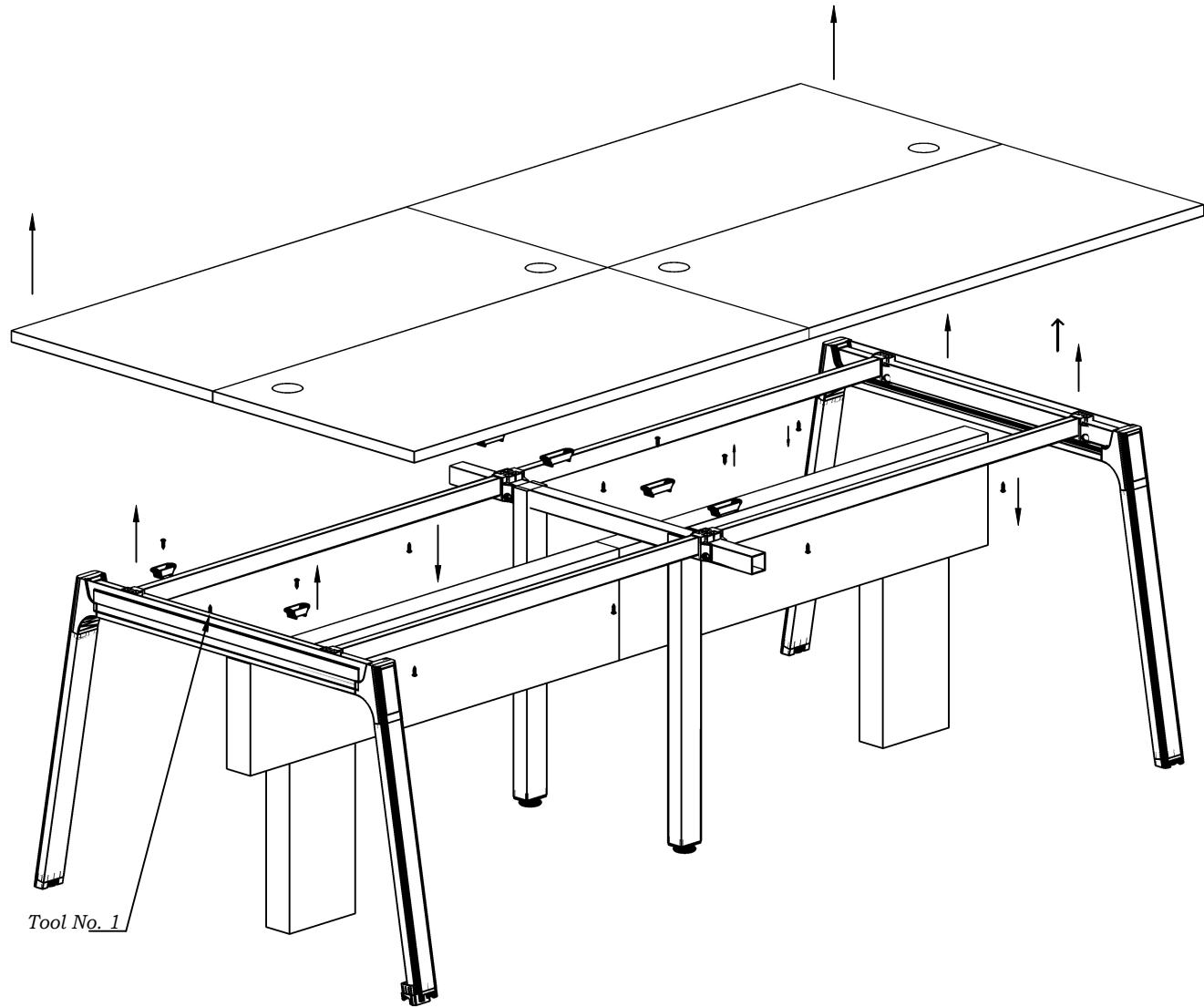
STEP 3 : SCREEN HOLDER REMOVE

Featherlite[®]



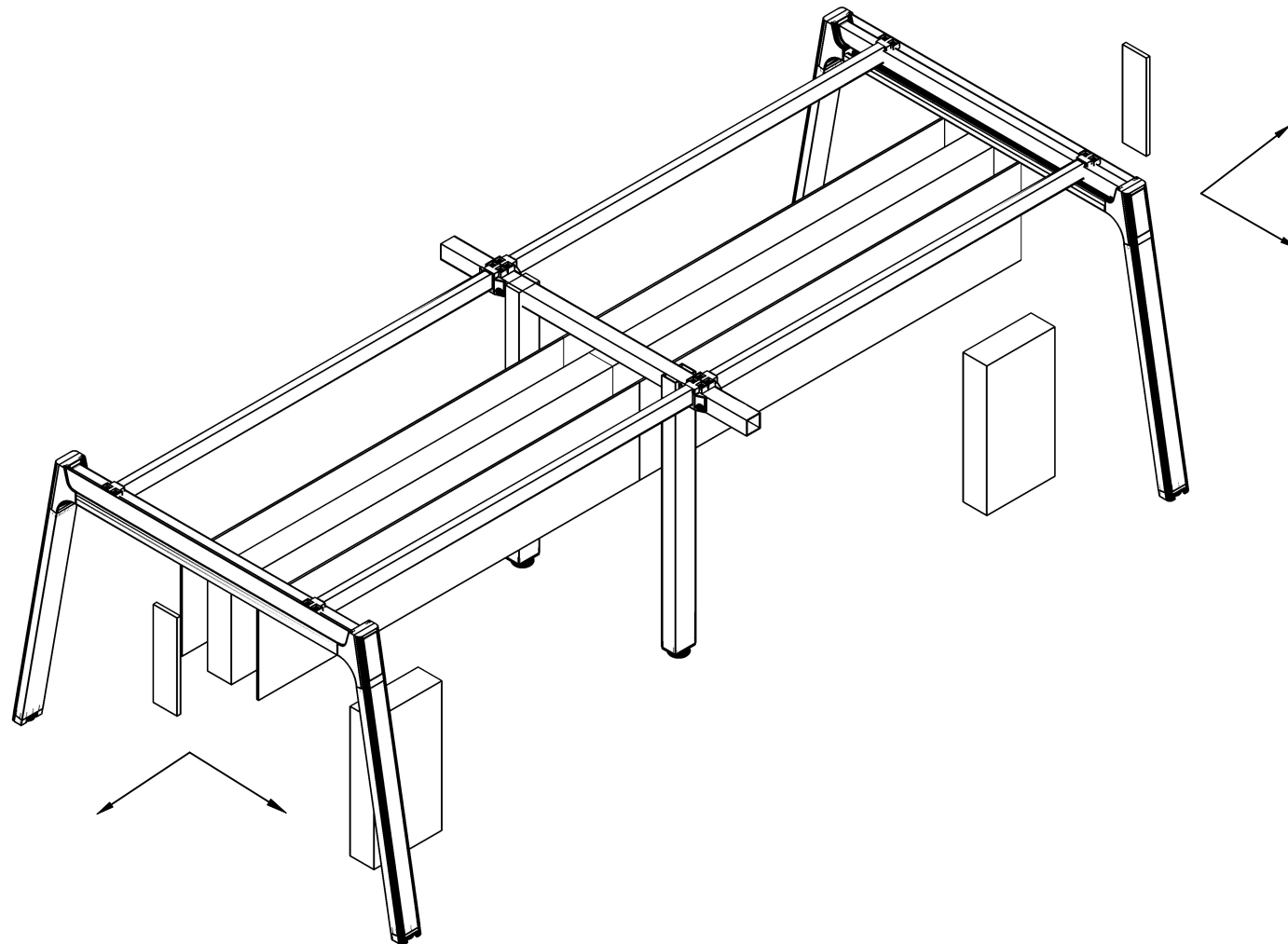
STEP 4 : TABLE TOP & SPACER REMOVAL

Featherlite[®]



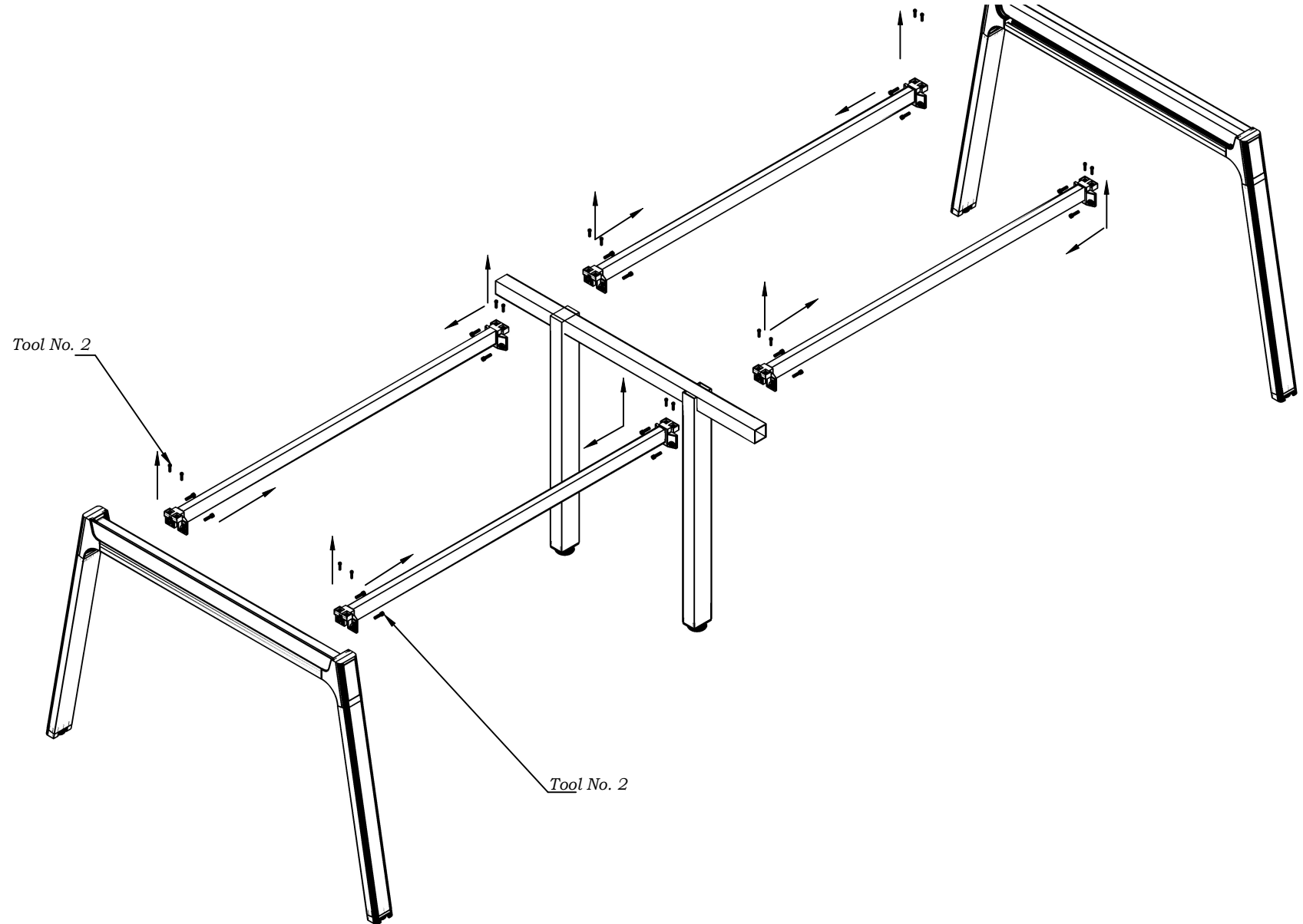
STEP 5 : RACEWAY/SIDE TRIM REMOVAL

Featherlite[®]



STEP 6 : CROSS BEAM & LEG ASSEMBLY REMOVAL

Featherlite[®]



Dis assembly instrcutions.

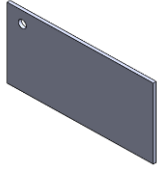
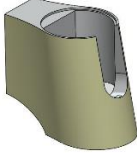
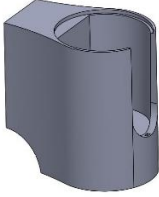
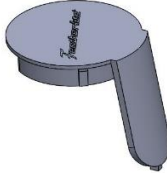
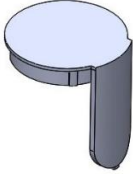

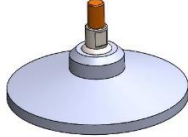
Disassembly Sequence, Time Schedule and Tools Requirement for COLOURS Desking System.




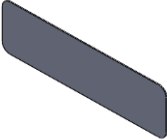
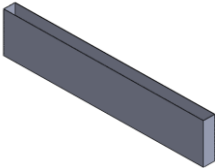
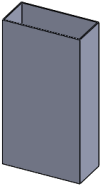



Table 1

<u>Sl.No</u>	<u>Activity</u>	<u>Time in min</u>	<u>Tools required</u>
1.	Disconnect sockets/switches and take out the cables.	4	Cordless Machine
2.	Remove the screens	3	Cordless Machine
3.	Remove Table Top	3	Cordless Machine
4.	Remove race way covers	2	Manual
5.	Remove the vertical wire management raceway.	3	Cordless Machine
6.	Remove Raceway frames.	3	Cordless Machine
7.	Remove cross beams	3	Allen Keys.
8.	Remove spacers.	2	Cordless Machine
9.	Remove leg supports.	2	Manual
10.	Remove accessories.	3	Cordless Machine
11.	Pack all components	4	Manual

Total time per work station- 32 Mins.

The timings are based on a cluster of 4 work stations. The dismantling team consists of two persons. For dismantling more number of work stations, larger team can be used and the activity can be telescoped.

Components Used in Connect Desking System		
SL. No.	Components name	Images
1	Table Top	
2	Connct 10 deg connector	
3	Connct 90 deg connector	
4	10 deg coonector cap	
5	90 Deg connector cap	
6	Connct leg bush	
7	Connct leg leveler	

8	Connct Leg	
9	Connct Leg beam tube Section	
10	Centre screen holder	
11	Screen	
12	MS Raceway	
13	Vetical Wire entery	
14	M6x 20 Allen Flange Head	
15	10X19 Pan head Screw	
16	50mm Spacer	

TOOLS USED IN INSTALLATION

Tool No. Name of the tool

Image

1 Cordless Machine



2 Cordless Machine



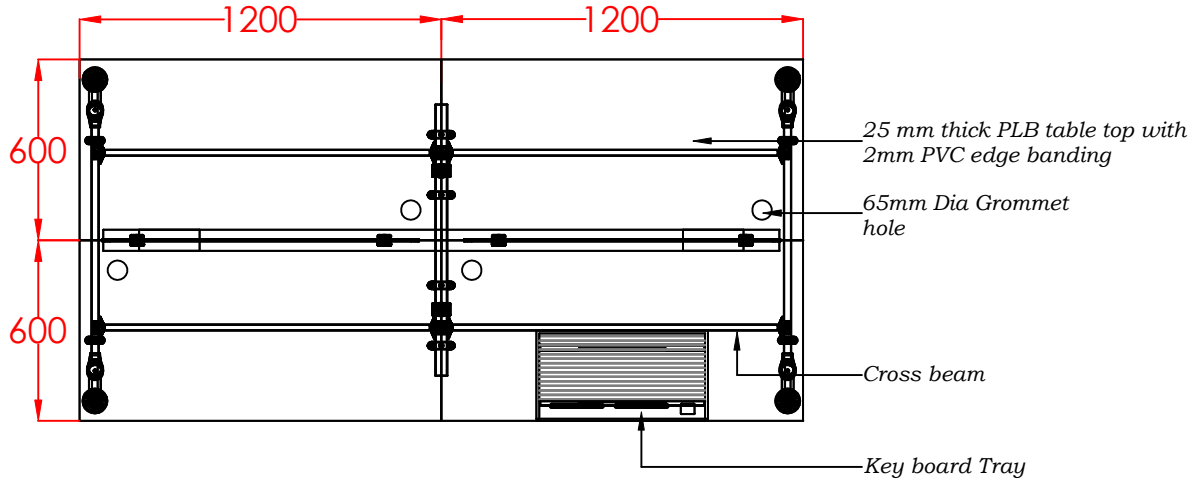
3 Rubber Mallet



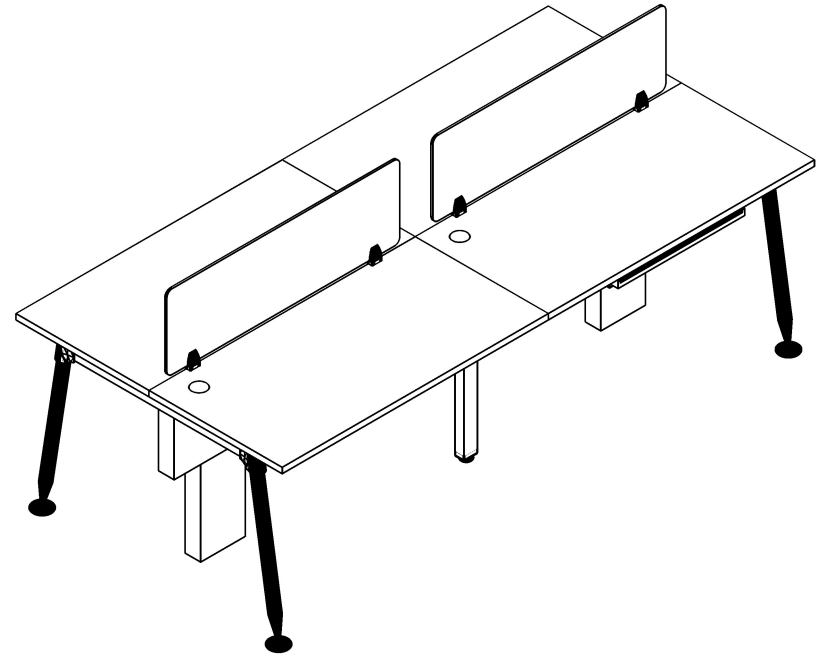
CONNECT SYSTEM - FULLY ASSEMBLED

Featherlite®

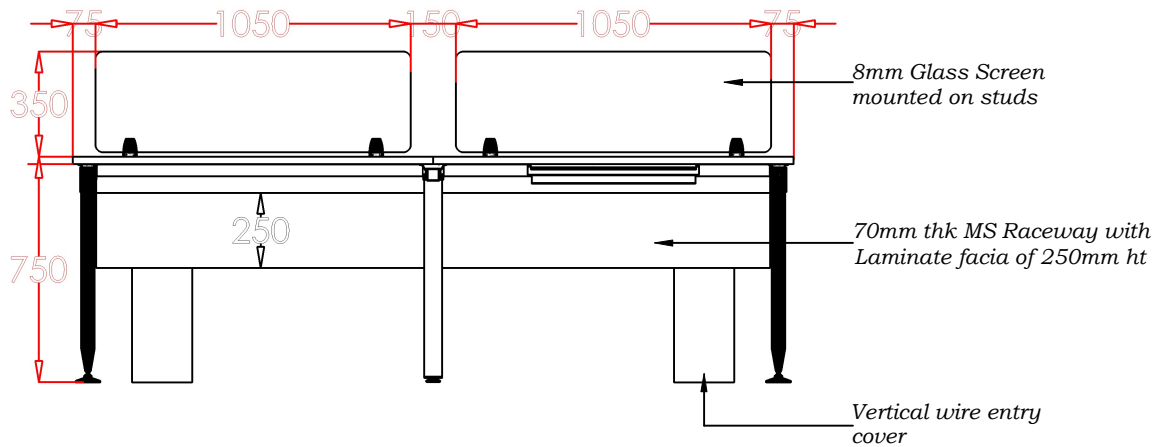
TOP VIEW



ISOMETRIC VIEW

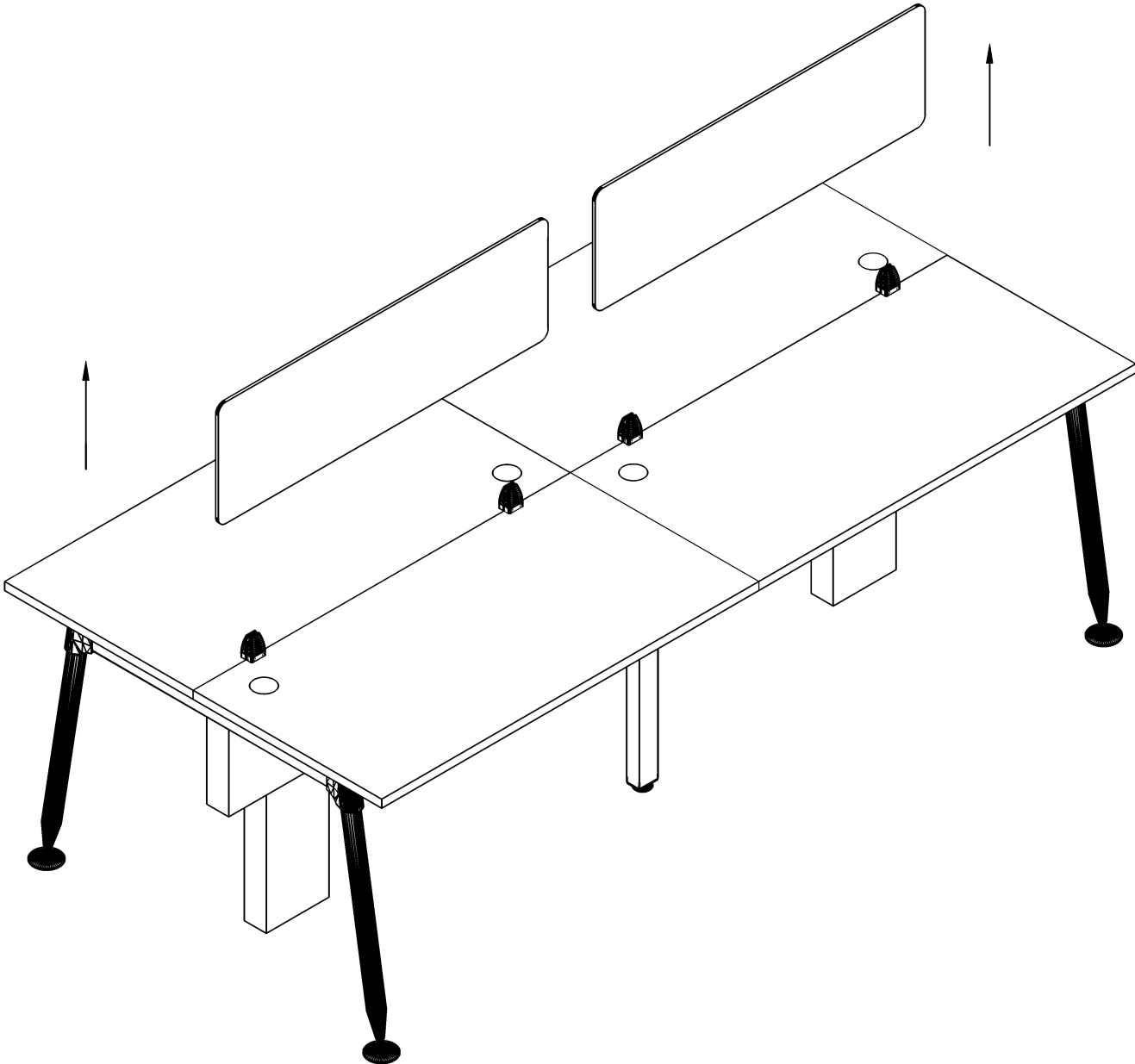


FRONT VIEW



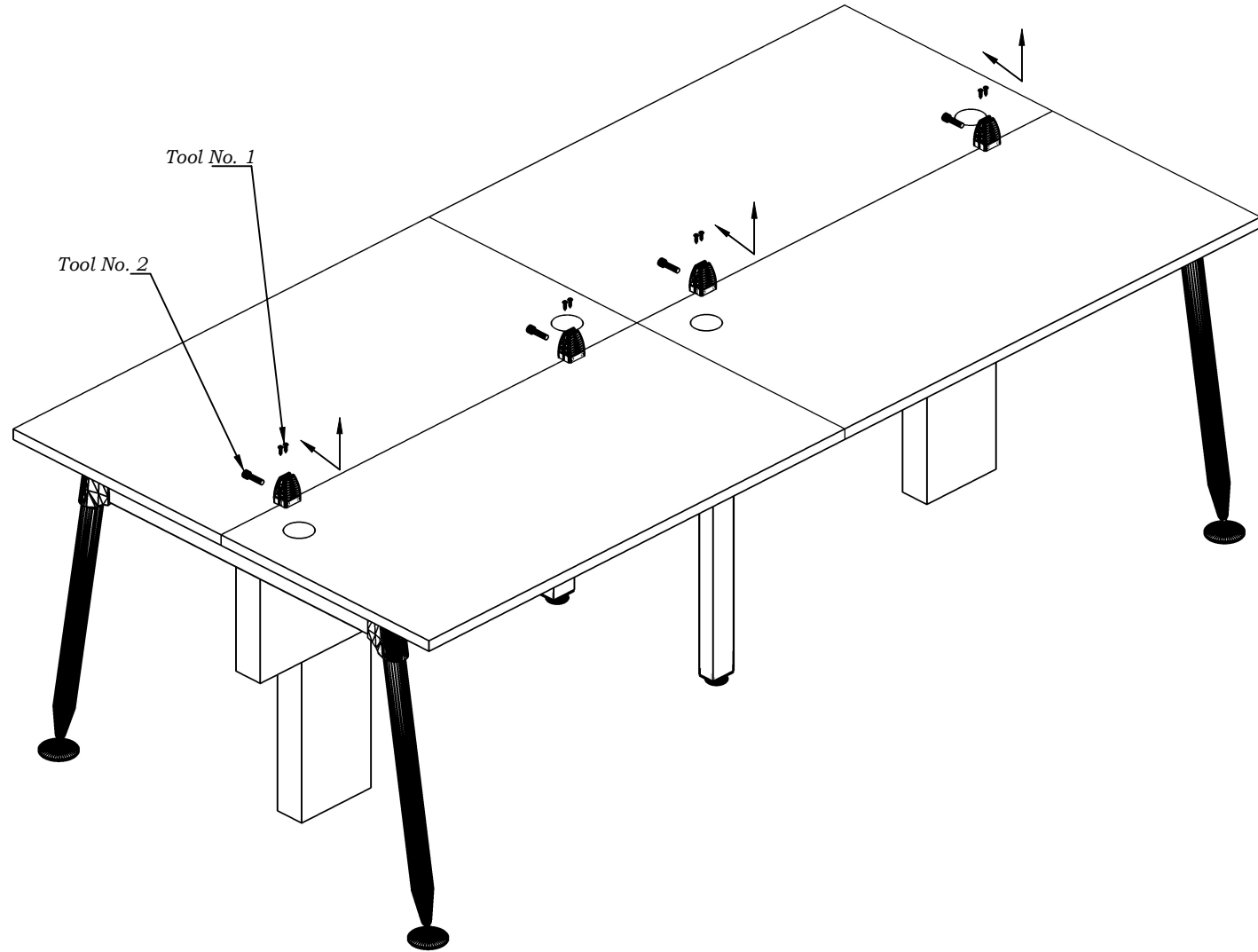
STEP 1 : SCREEN REMOVAL

Featherlite[®]



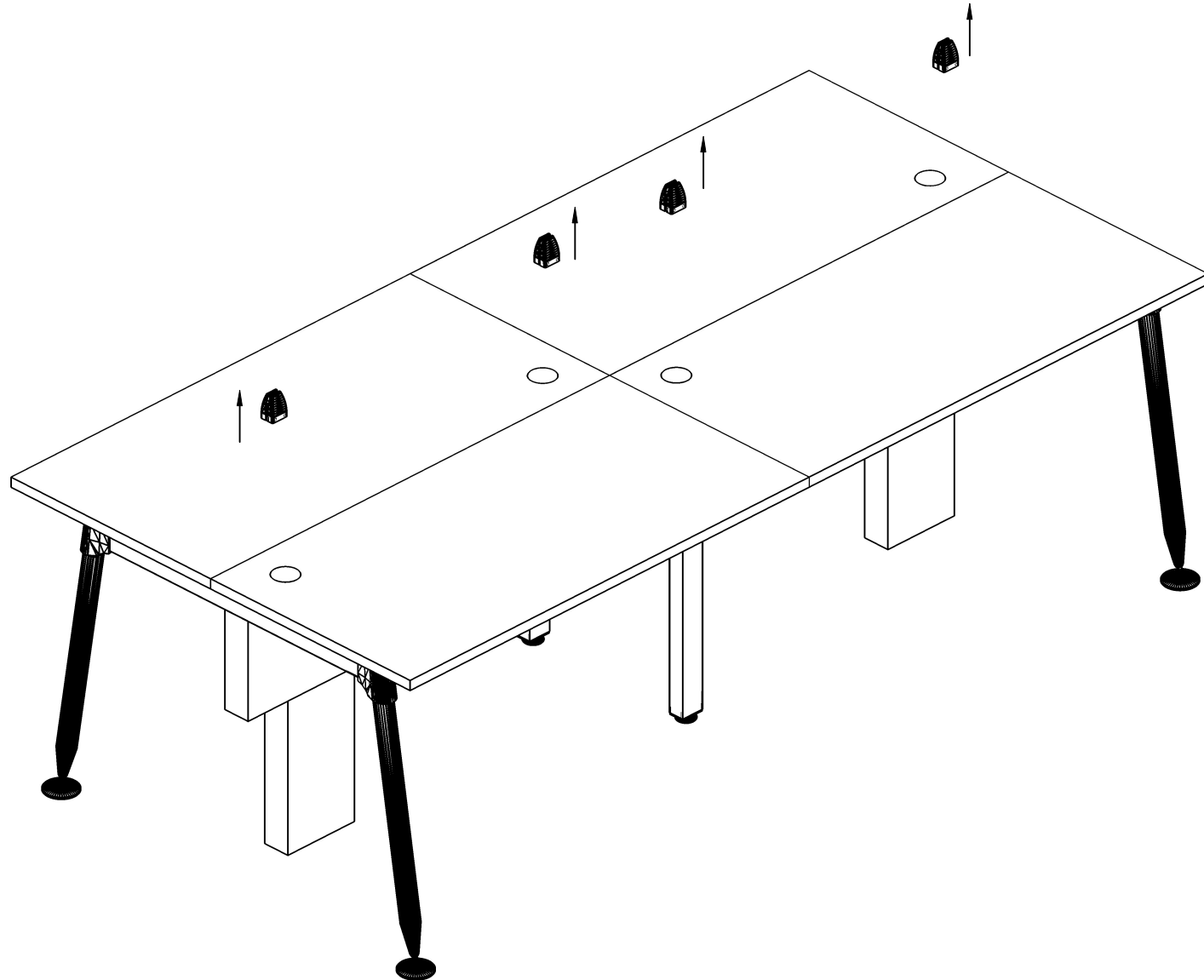
STEP 2 : SCREEN HOLDER SCREWS REMOVE

Featherlite[®]



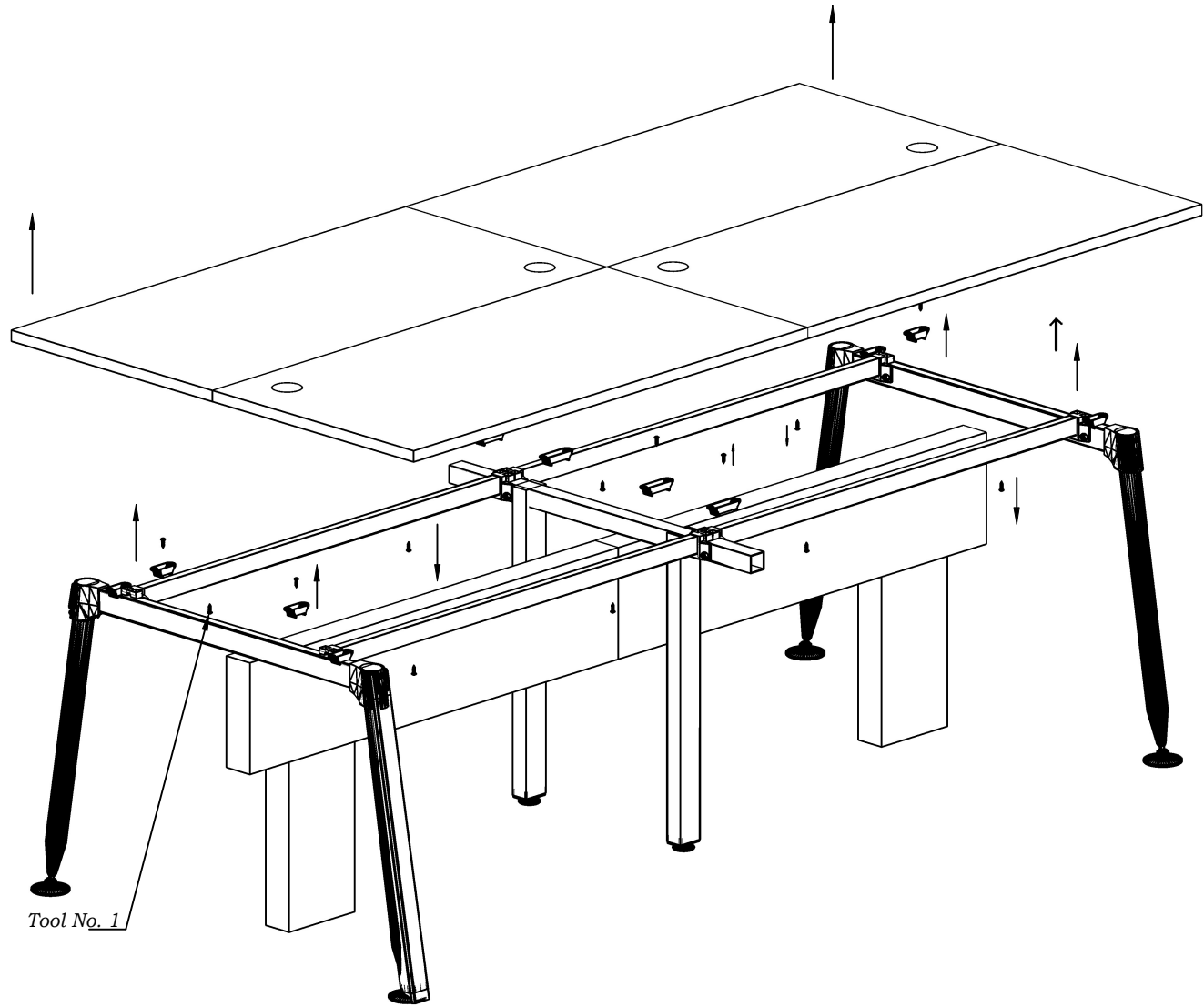
STEP 3 : SCREEN HOLDER REMOVE

Featherlite[®]



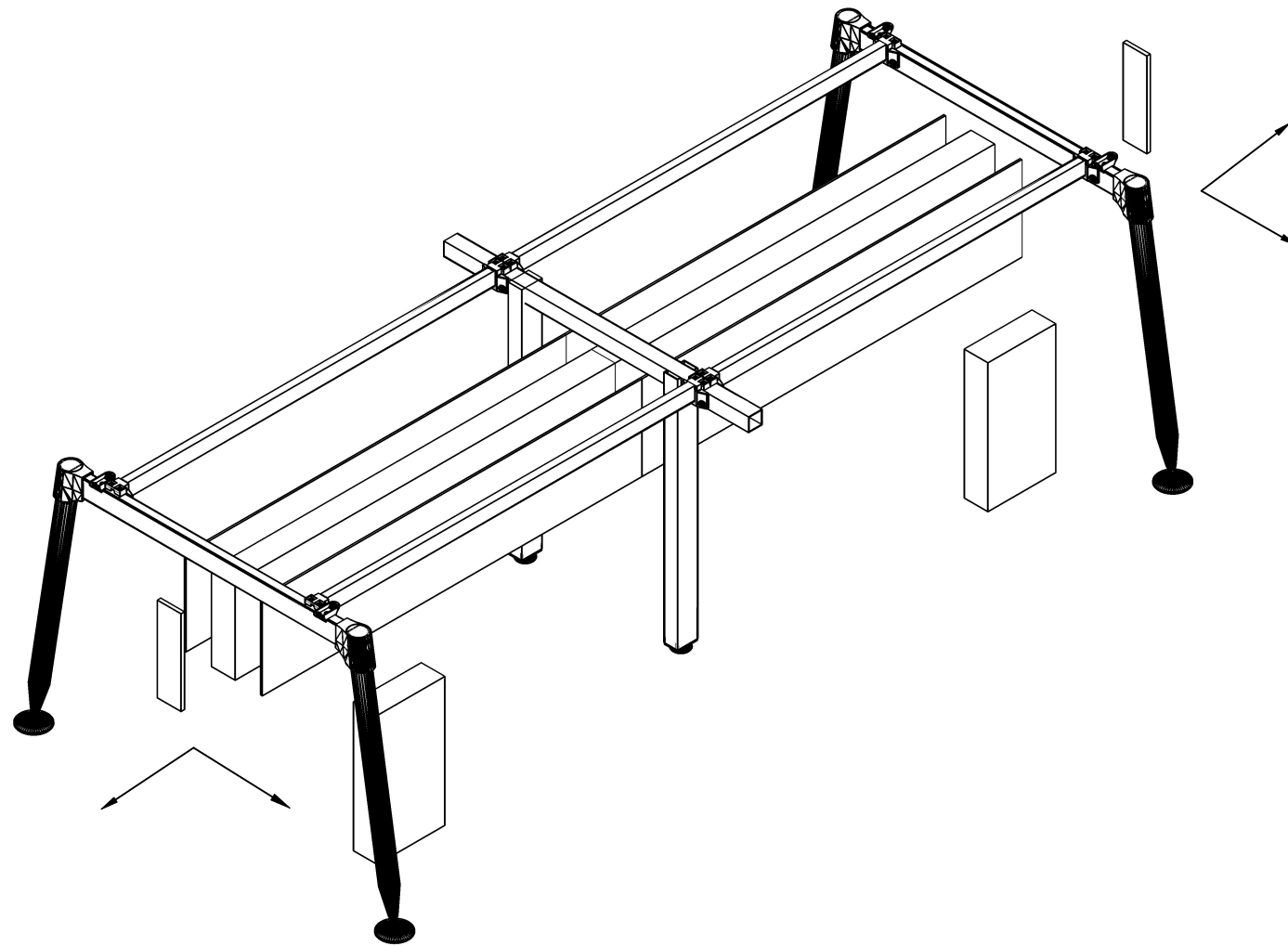
STEP 4 : TABLE TOP & SPACER REMOVAL

Featherlite[®]



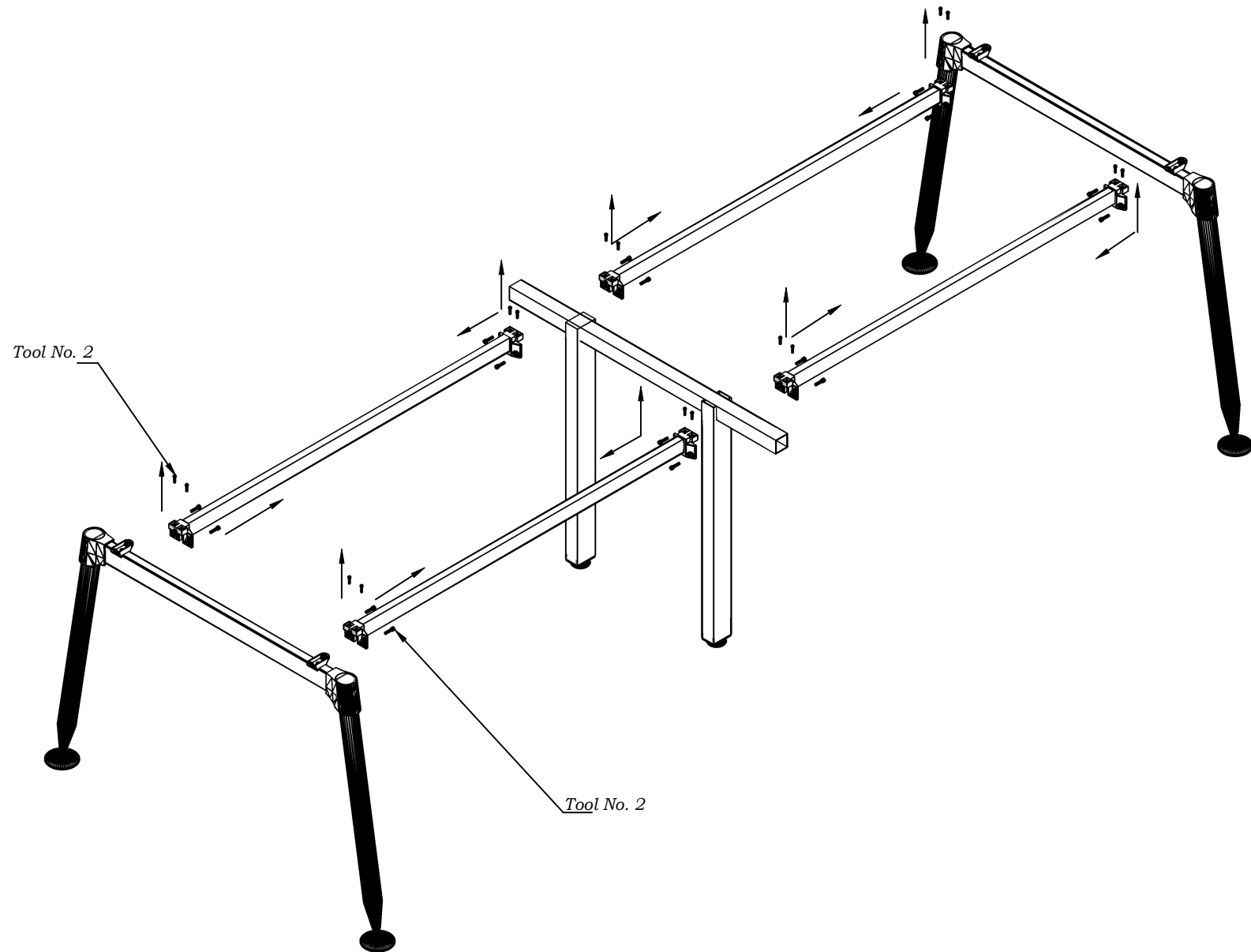
STEP 5 : RACEWAY/SIDE TRIM REMOVAL

Featherlite[®]



STEP 6 : CROSS BEAM & LEG ASSEMBLY REMOVAL

Featherlite®



Dis assembly instrcutions.

Disassembly Sequence, Time Schedule and Tools Requirement for CONNECT Desking System.

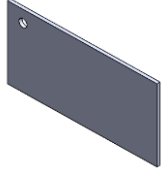
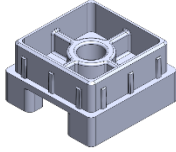
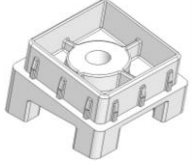
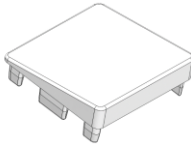
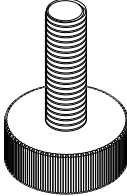


Table 1

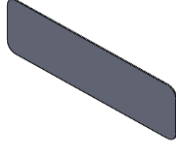
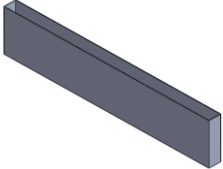
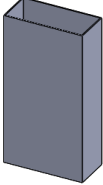


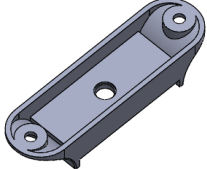
<u>Sl.No</u>	<u>Activity</u>	<u>Time in min</u>	<u>Tools required</u>
1.	Disconnect sockets/switches and take out the cables.	4	Cordless Machine
2.	Remove the screens	3	Cordless Machine
3.	Remove Table Top	3	Cordless Machine
4.	Remove race way covers	2	Manual
5.	Remove the vertical wire management raceway.	3	Cordless Machine
6.	Remove Raceway frames.	3	Cordless Machine
7.	Remove cross beams	3	Allen Keys.
8.	Remove spacers.	2	Cordless Machine
9.	Remove leg supports.	2	Manual
10.	Remove accessories.	3	Cordless Machine
11.	Pack all components	4	Manual

Total time per work station- 32 Mins.

The timings are based on a cluster of 4 work stations. The dismantling team consists of two persons. For dismantling more number of work stations, larger team can be used and the activity can be telescoped.

Components Used in Perform Desking System

SL. No.	Components name	Images
1	Table Top	
2	Perform 90 deg leg shoe	
3	Perform 10 deg leg shoe	
4	Perform 10 deg leg cap	
5	Leg leveler	
6	Perform Leg beam tube Section	
7	Centre screen holder	

8	Screen	
9	MS Raceway	
10	Vertical Wire entry	
11	M6x 20 Allen Flange Head	
12	10X19 Pan head Screw	
13	50mm Spacer	

TOOLS USED IN INSTALLATION

Tool No. Name of the tool

Image

1 Cordless Machine



2 Cordless Machine



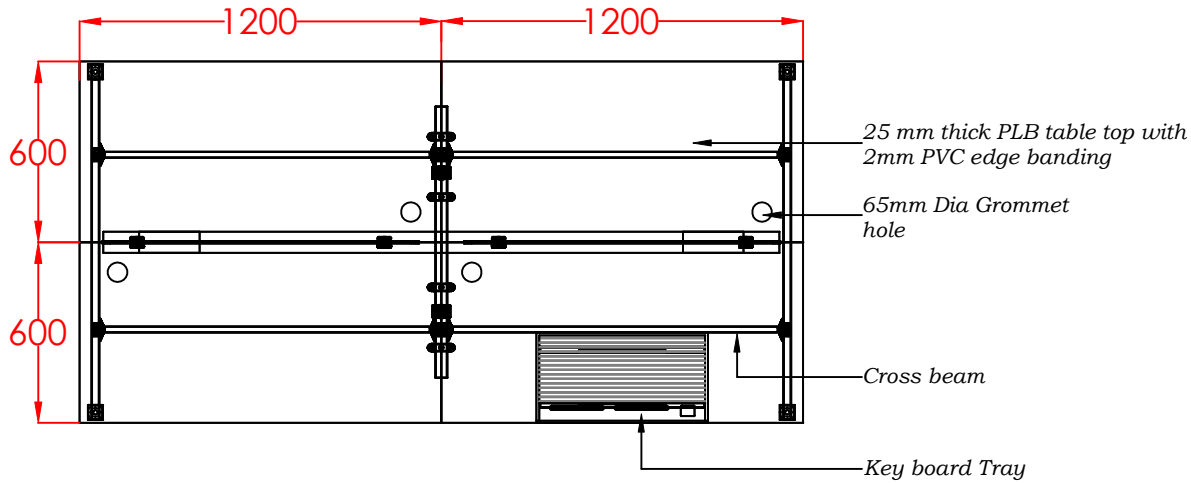
3 Rubber Mallet



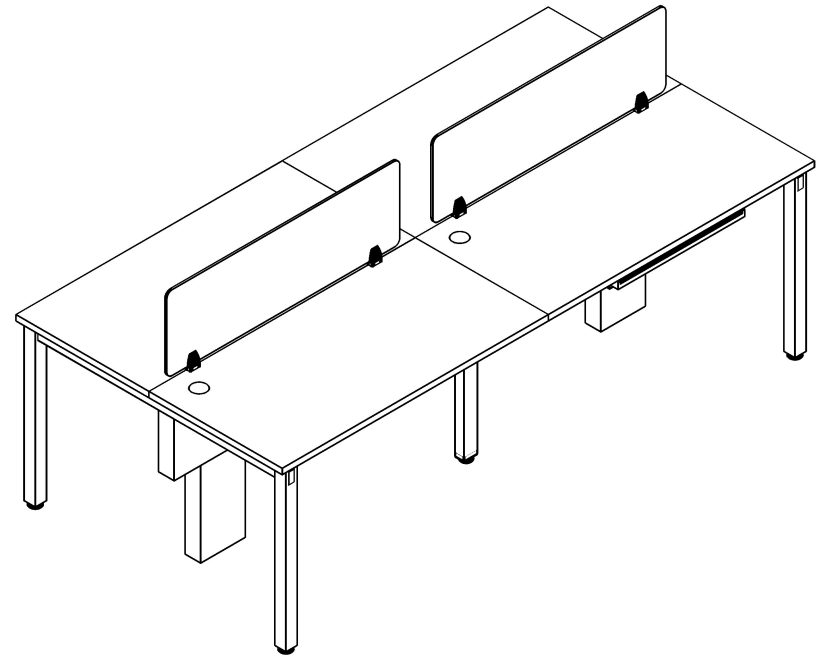
PERFORM SYSTEM - FULLY ASSEMBLED

Featherlite®

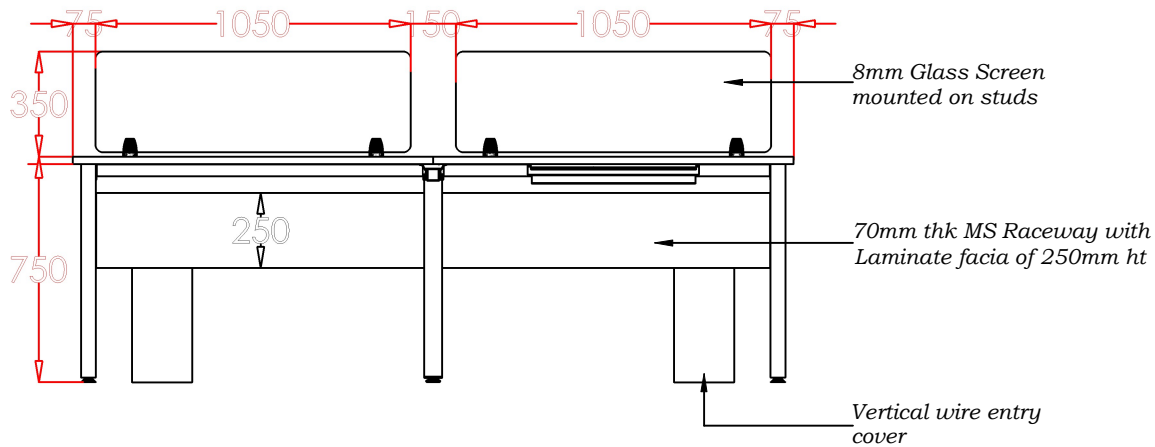
TOP VIEW



ISOMETRIC VIEW

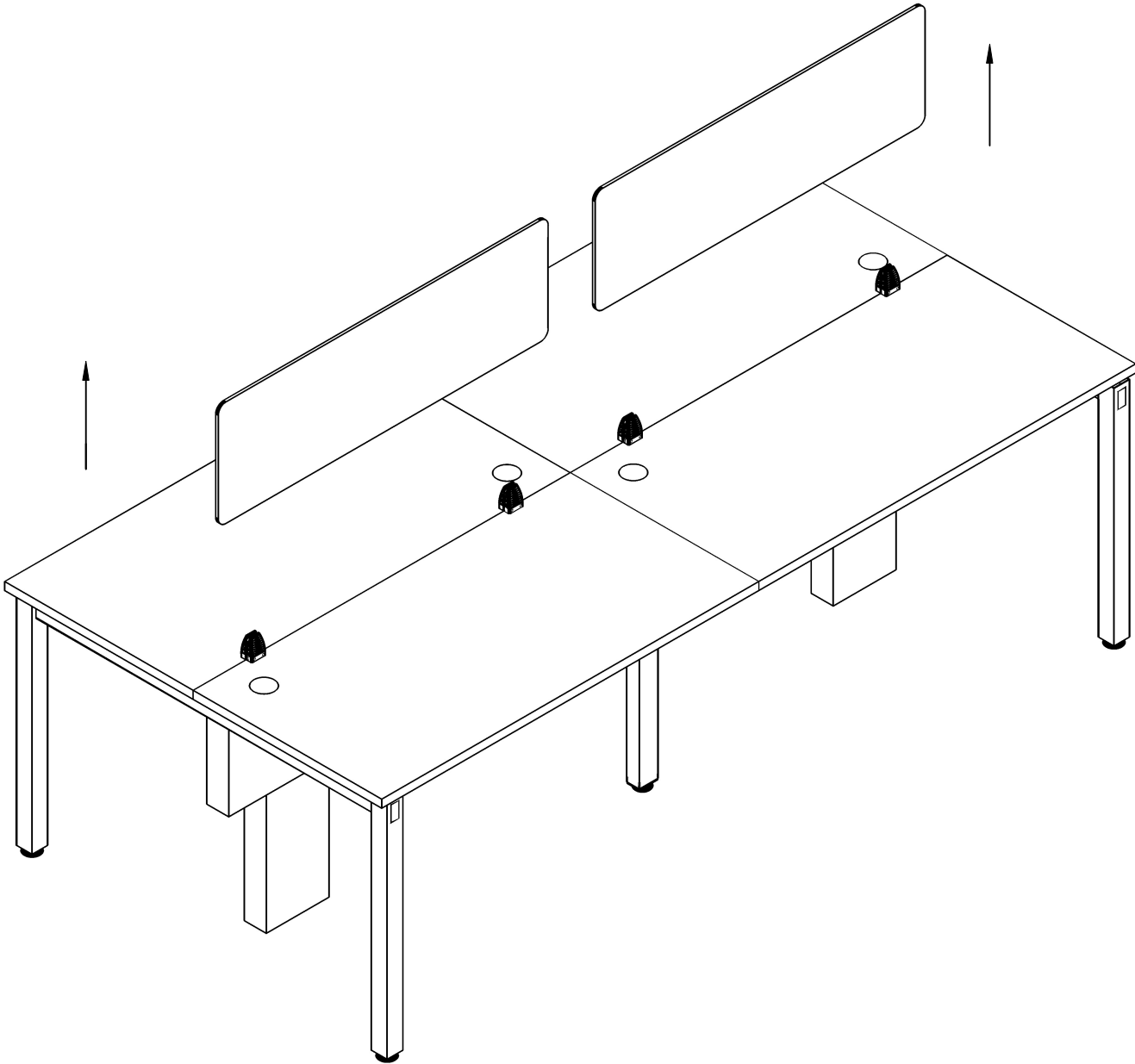


FRONT VIEW



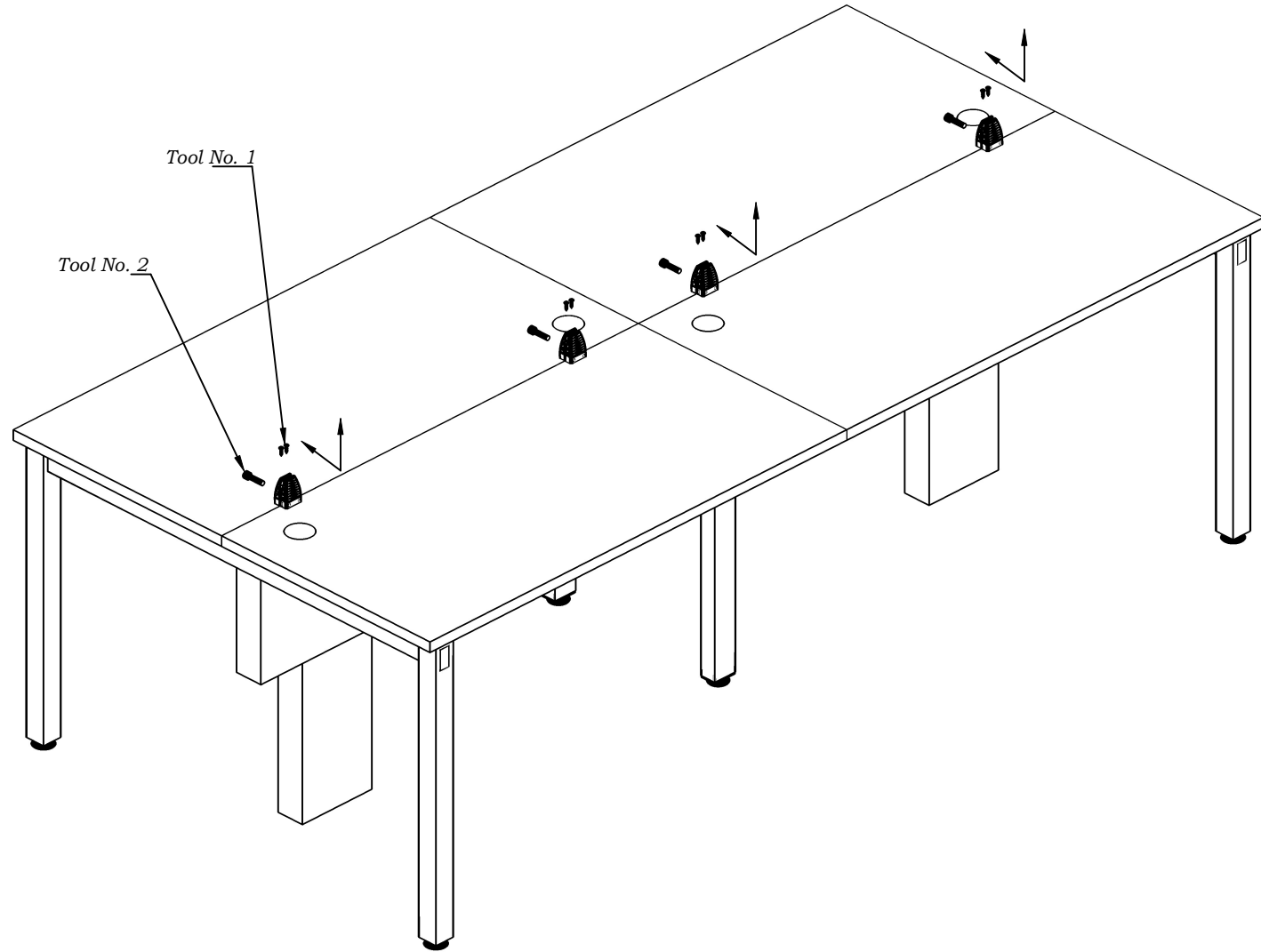
STEP 1 : SCREEN REMOVAL

Featherlite[®]



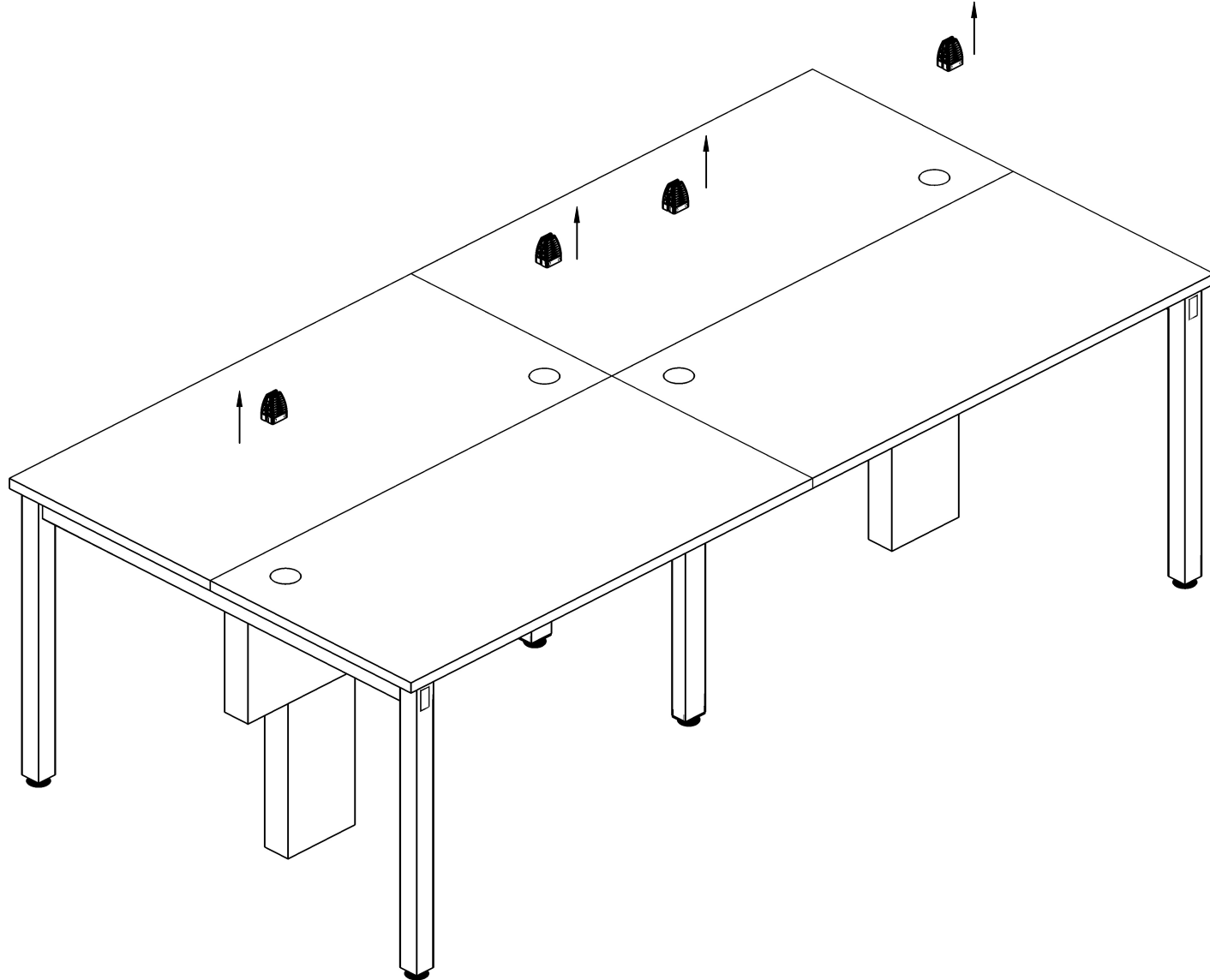
STEP 2 : SCREEN HOLDER SCREWS REMOVE

Featherlite[®]



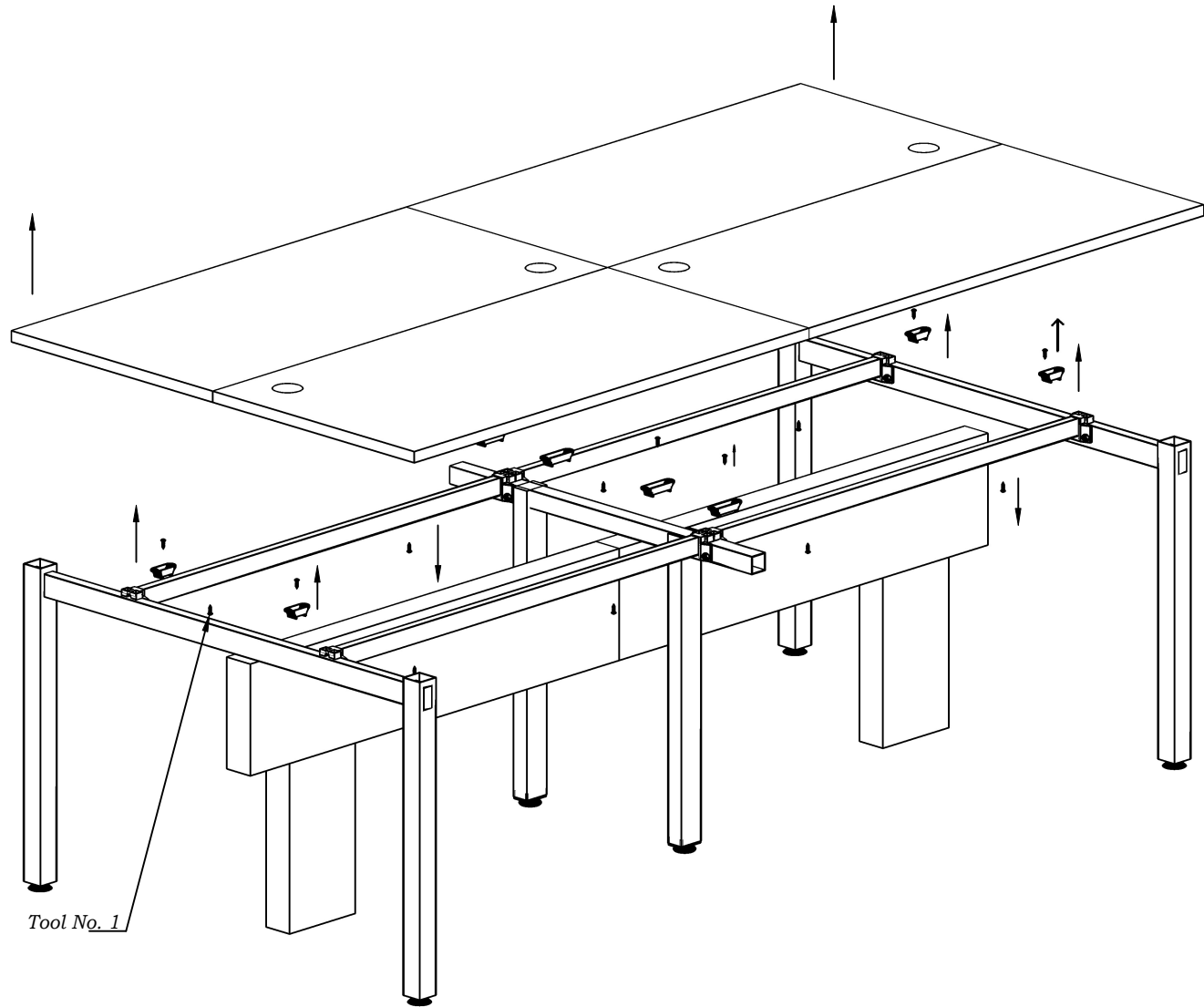
STEP 3 : SCREEN HOLDER REMOVE

Featherlite[®]



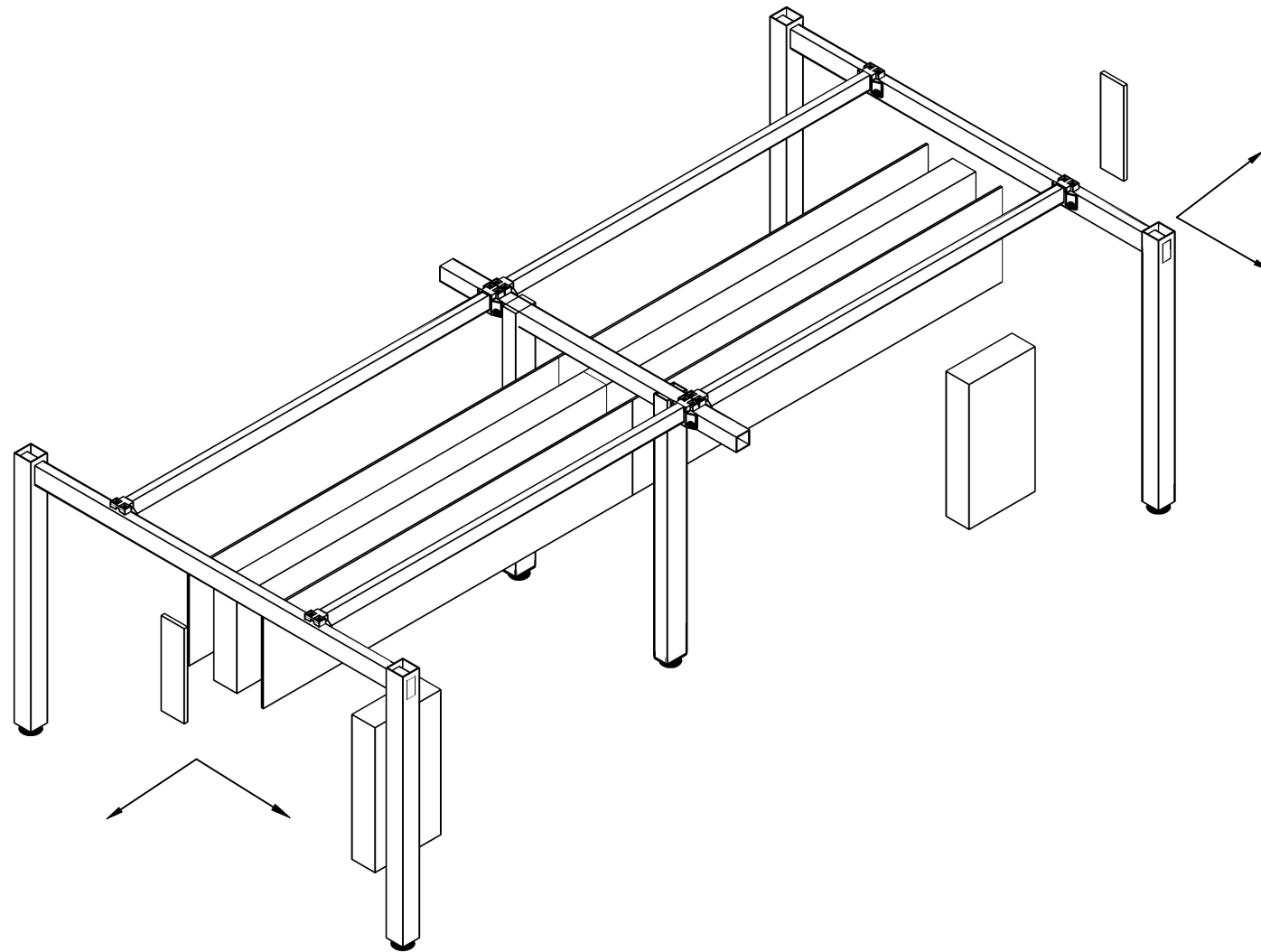
STEP 4 : TABLE TOP & SPACER REMOVAL

Featherlite[®]



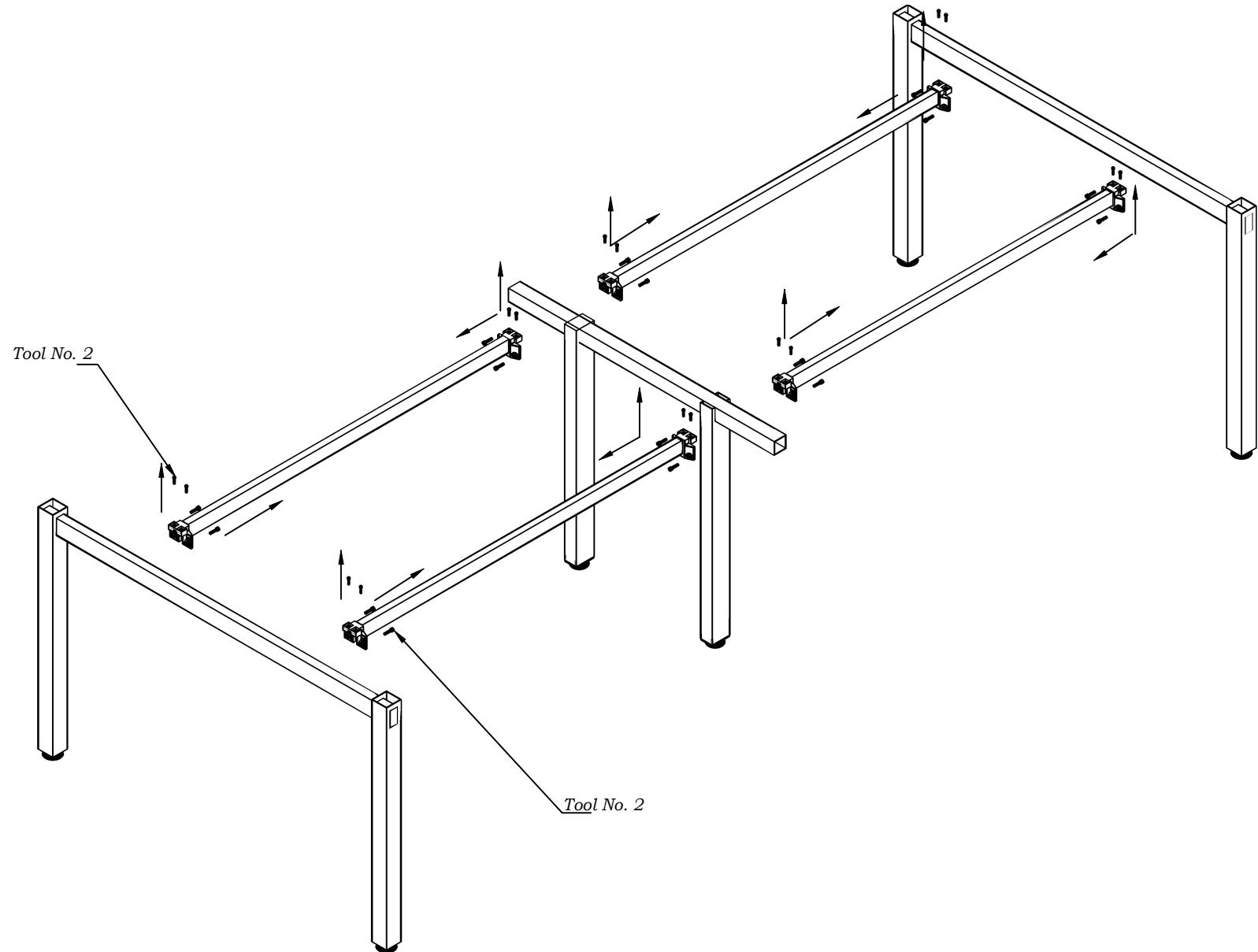
STEP 5 : RACEWAY/SIDE TRIM REMOVAL

Featherlite[®]



STEP 6 : CROSS BEAM & LEG ASSEMBLY REMOVAL

Featherlite[®]



Dis assembly instrcutions.

Disassembly Sequence, Time Schedule and Tools Requirement for PERFORM Desking System.

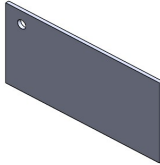
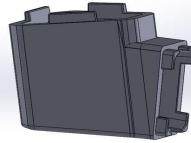
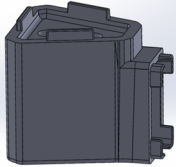
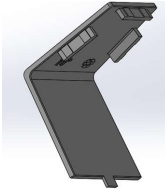
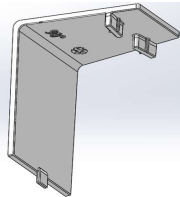
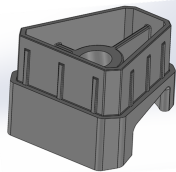
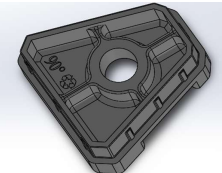
Table 1

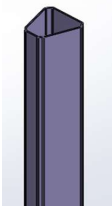
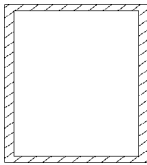

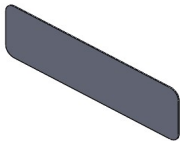
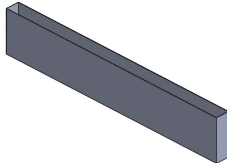
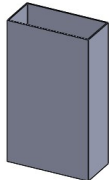
<u>Sl.No</u>	<u>Activity</u>	<u>Time in min</u>	<u>Tools required</u>
1.	Disconnect sockets/switches and take out the cables.	4	Cordless Machine
2.	Remove the screens	3	Cordless Machine
3.	Remove Table Top	3	Cordless Machine
4.	Remove race way covers	2	Manual
5.	Remove the vertical wire management raceway.	3	Cordless Machine
6.	Remove Raceway frames.	3	Cordless Machine
7.	Remove cross beams	3	Allen Keys.
8.	Remove spacers.	2	Cordless Machine
9.	Remove leg supports.	2	Manual
10.	Remove accessories.	3	Cordless Machine
11.	Pack all components	4	Manual

Total time per work station- 32 Mins.

The timings are based on a cluster of 4 work stations. The dismantling team consists of two persons. For dismantling more number of work stations, larger team can be used and the activity can be telescoped.




Components Used in Synergy Desking System

SL. No.	Components name	Images
1	Table Top	
2	Synergy 10 deg connector	
3	Synergy 90 deg connector	
4	10 deg coonector cap	
5	90 Deg connector cap	
6	10 deg leg shoe	
7	90 deg leg shoe	

8	Synergy Leg	
9	Synergy Leg beam tube Section	
10	Centre screen holder	
11	Screen	
12	MS Raceway	
13	Vertical Wire entry	

14	M6x 20 Allen Flange Head	
15	10X19 Pan head Screw	
16	50mm Spacer	

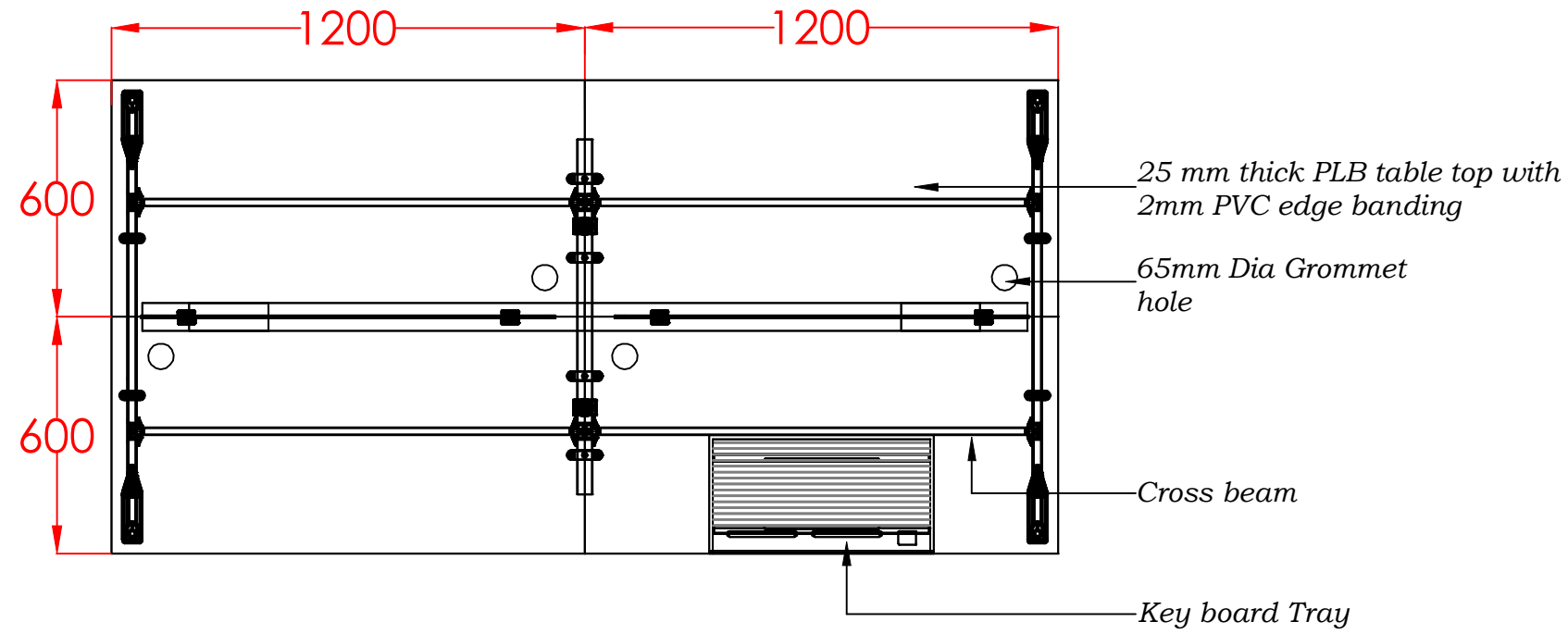
TOOLS USED IN INSTALLATION

Tool No.	Nanme of the tool	Image
1	Cordless Machine	
2	Cordless Machine	
3	Rubber Mallet	

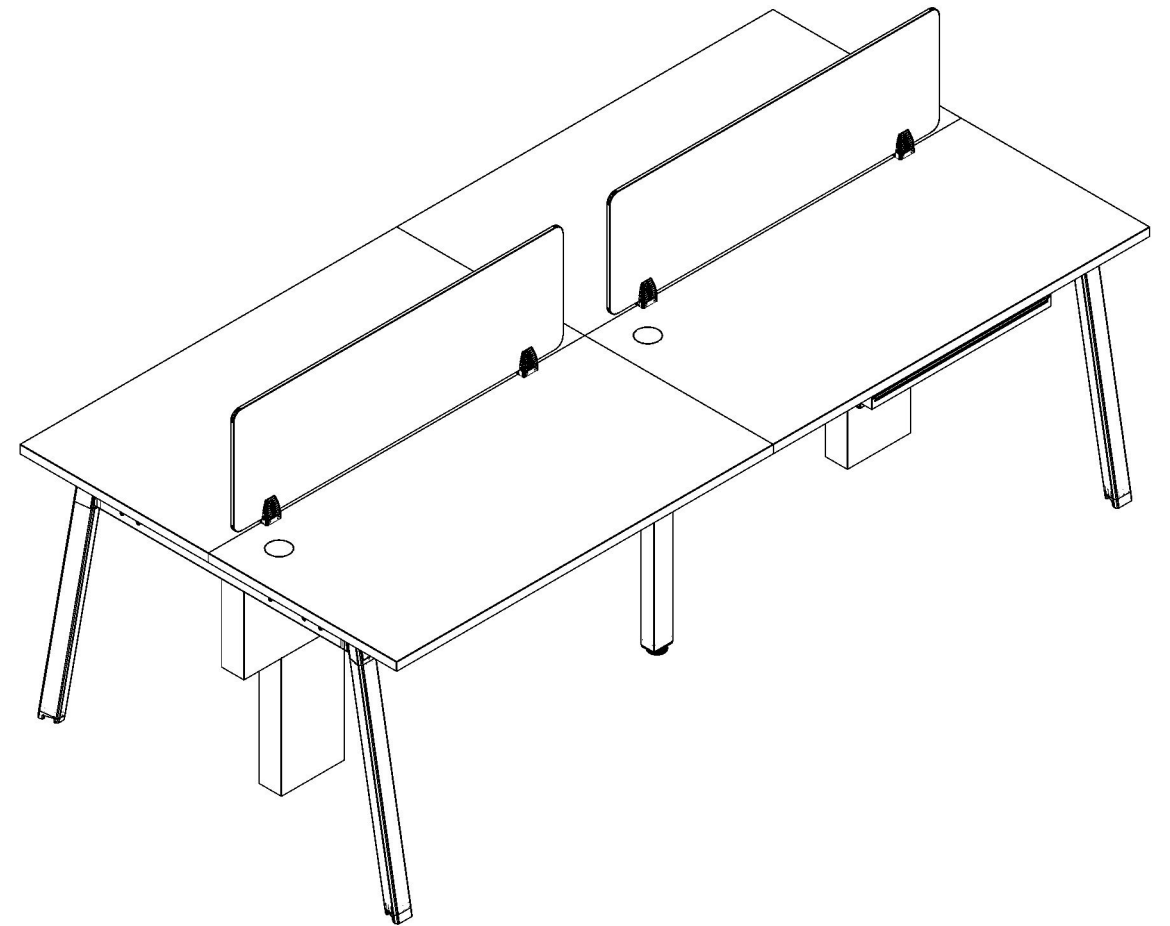
SYNERGY SYSTEM - FULLY ASSEMBLED

Featherlite[®]

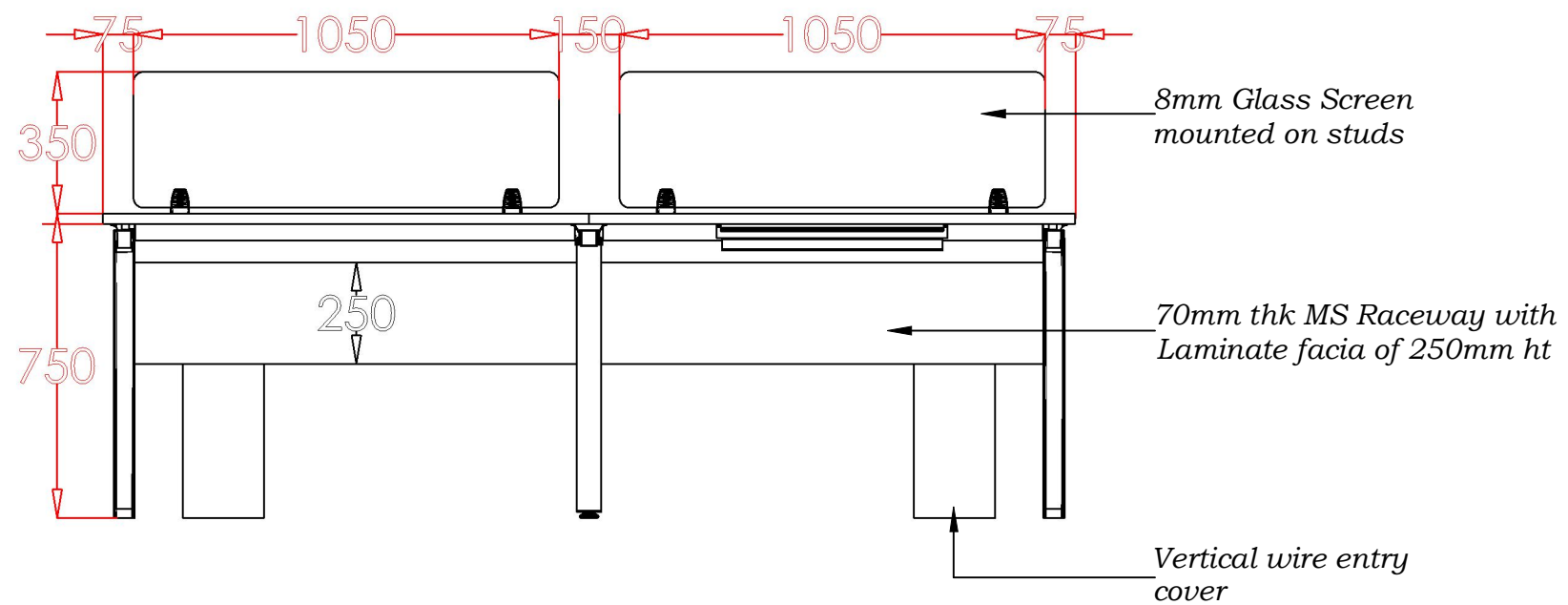
TOP VIEW



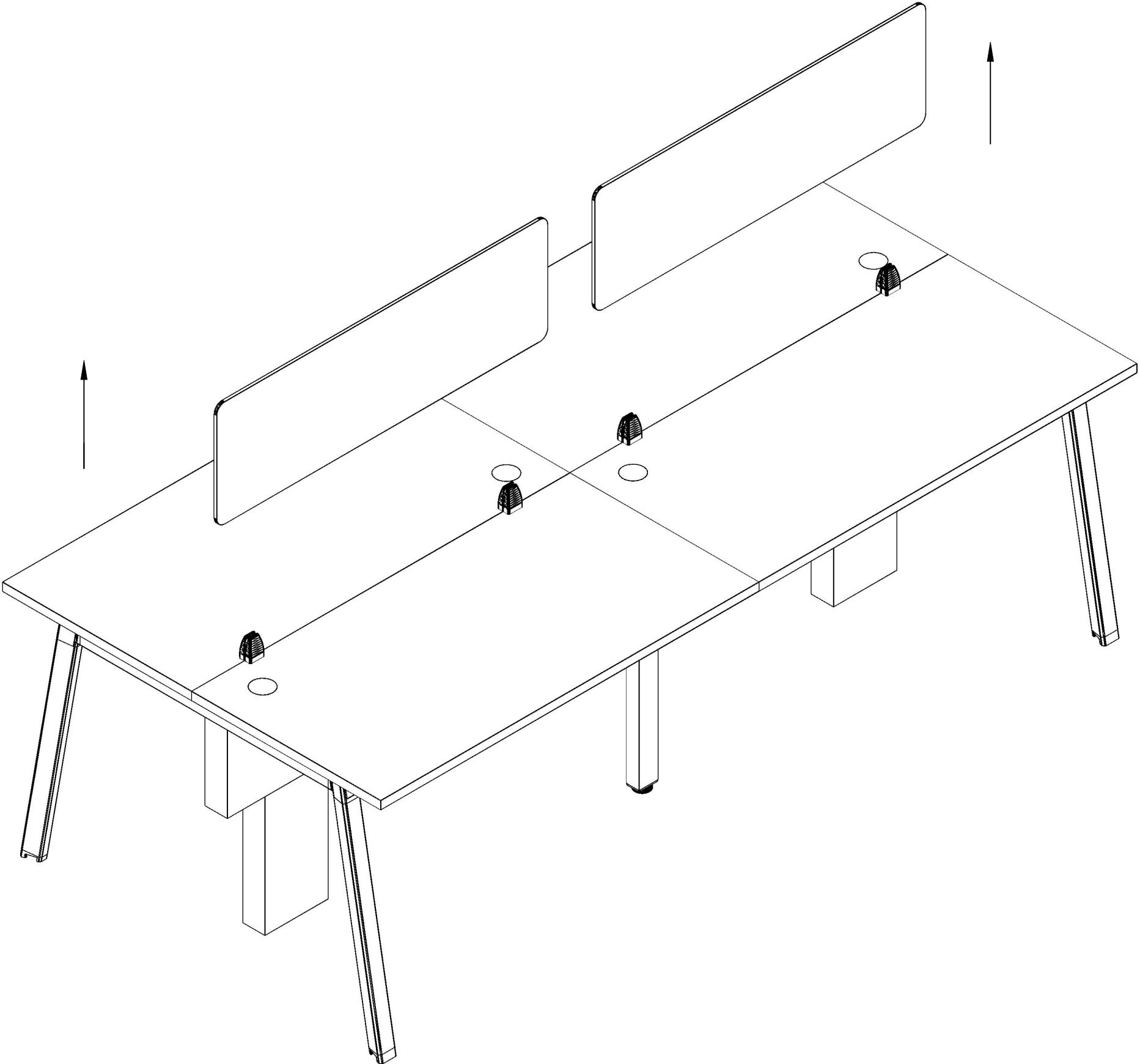
ISOMETRIC VIEW



FRONT VIEW

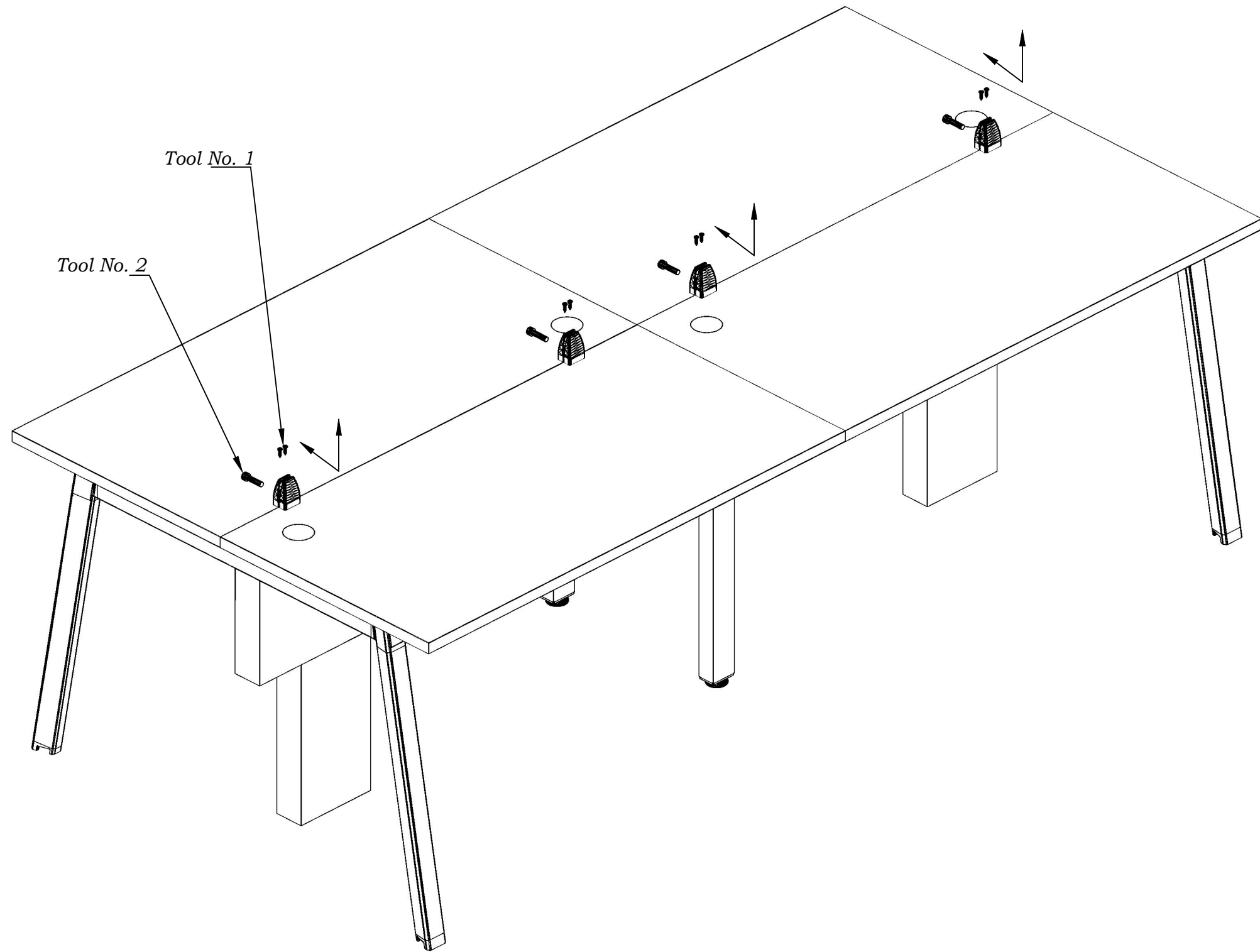


STEP 1 : SCREEN REMOVAL



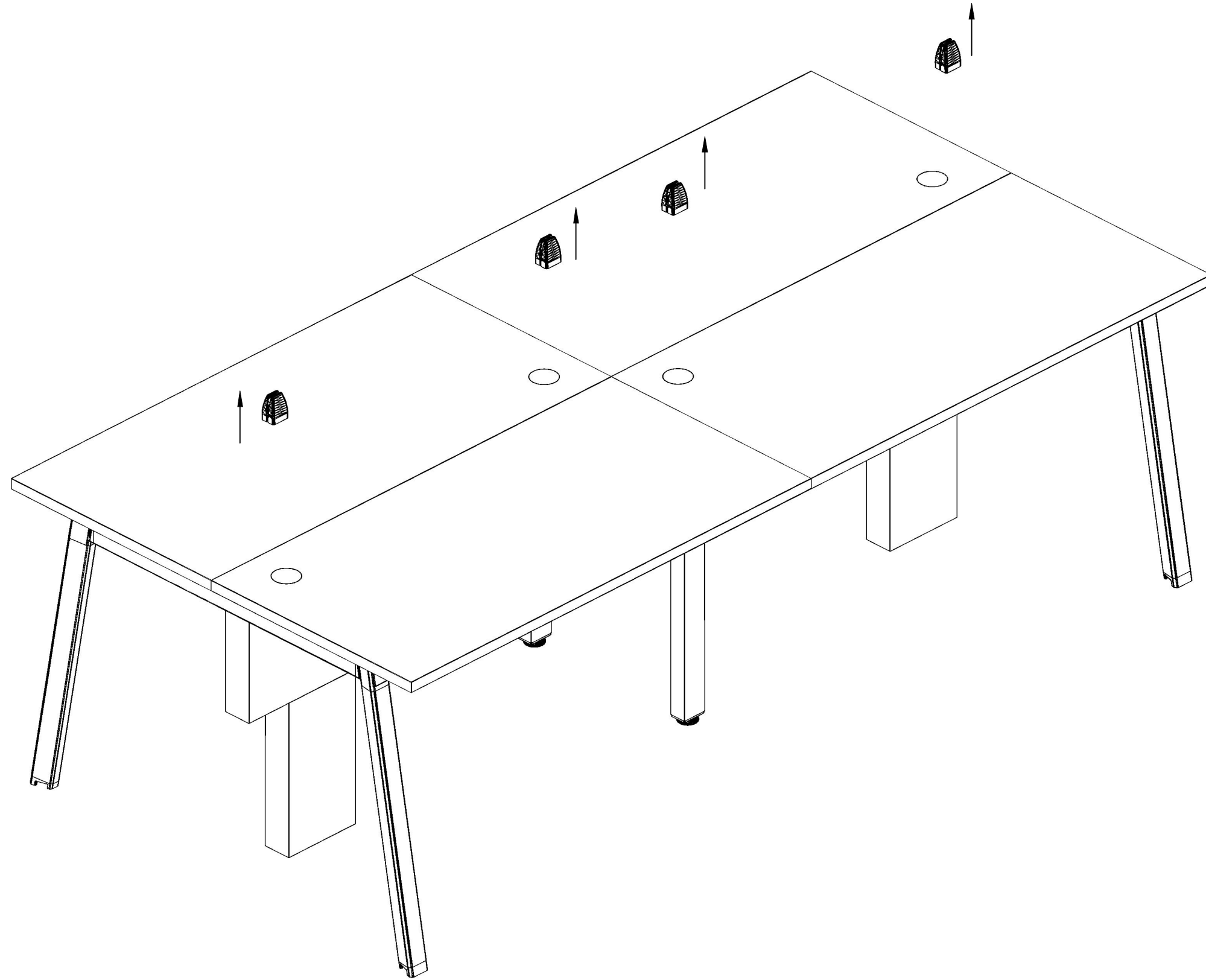
STEP 2 : SCREEN HOLDER SCREWS REMOVE

Featherlite[®]



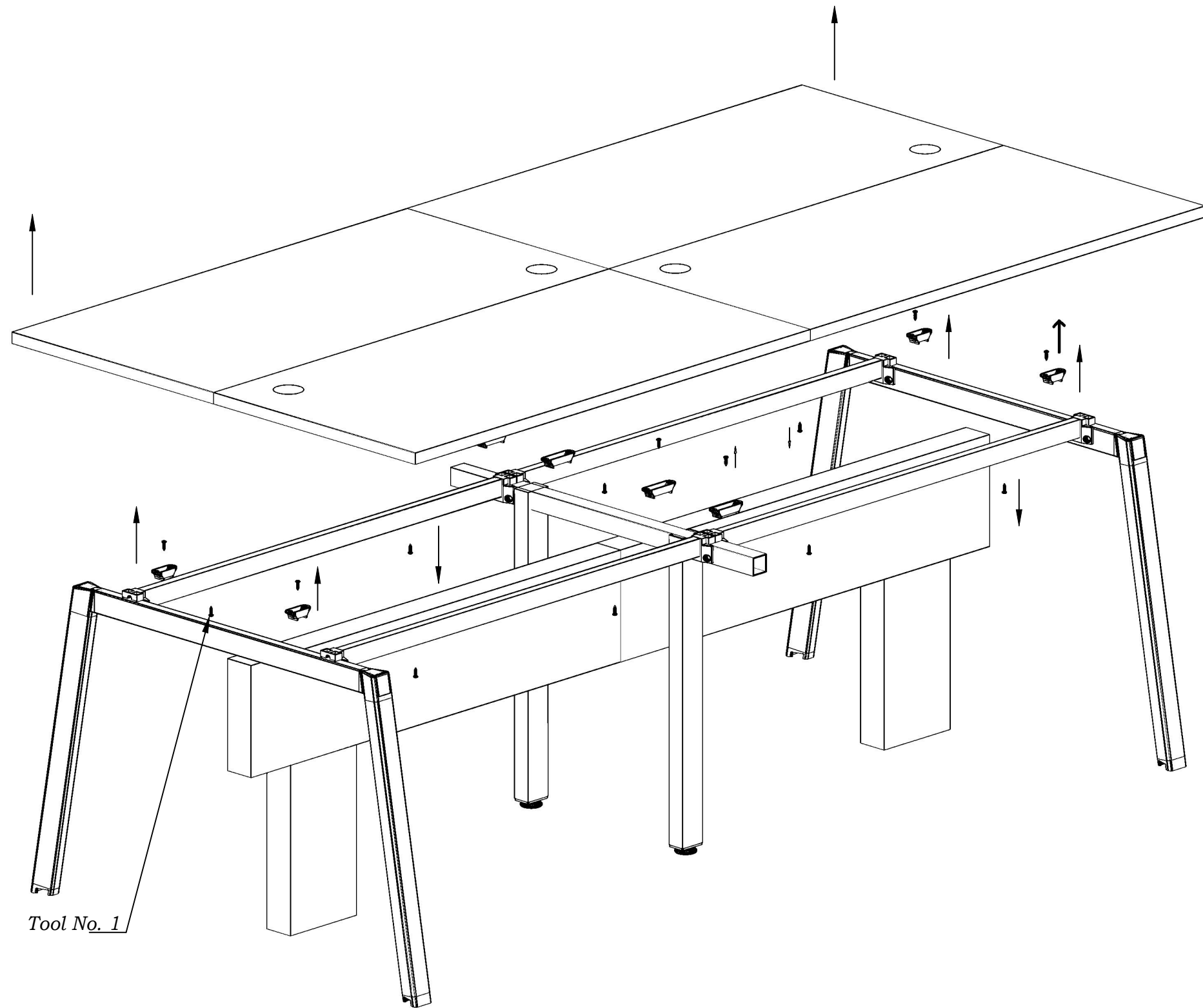
STEP 3 : SCREEN HOLDER REMOVE

Featherlite[®]



STEP 4 : TABLE TOP & SPACER REMOVAL

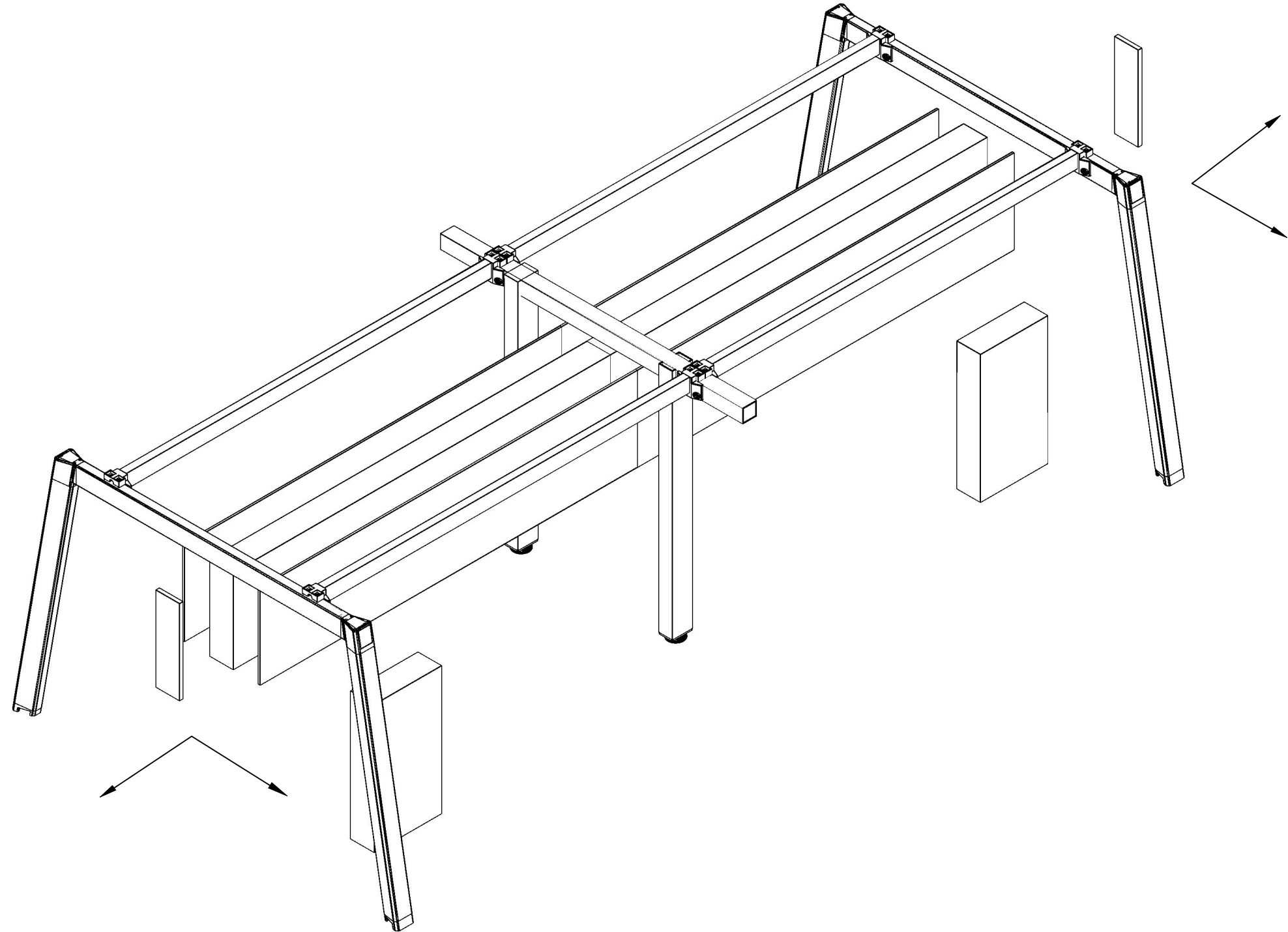
Featherlite[®]



Tool No. 1

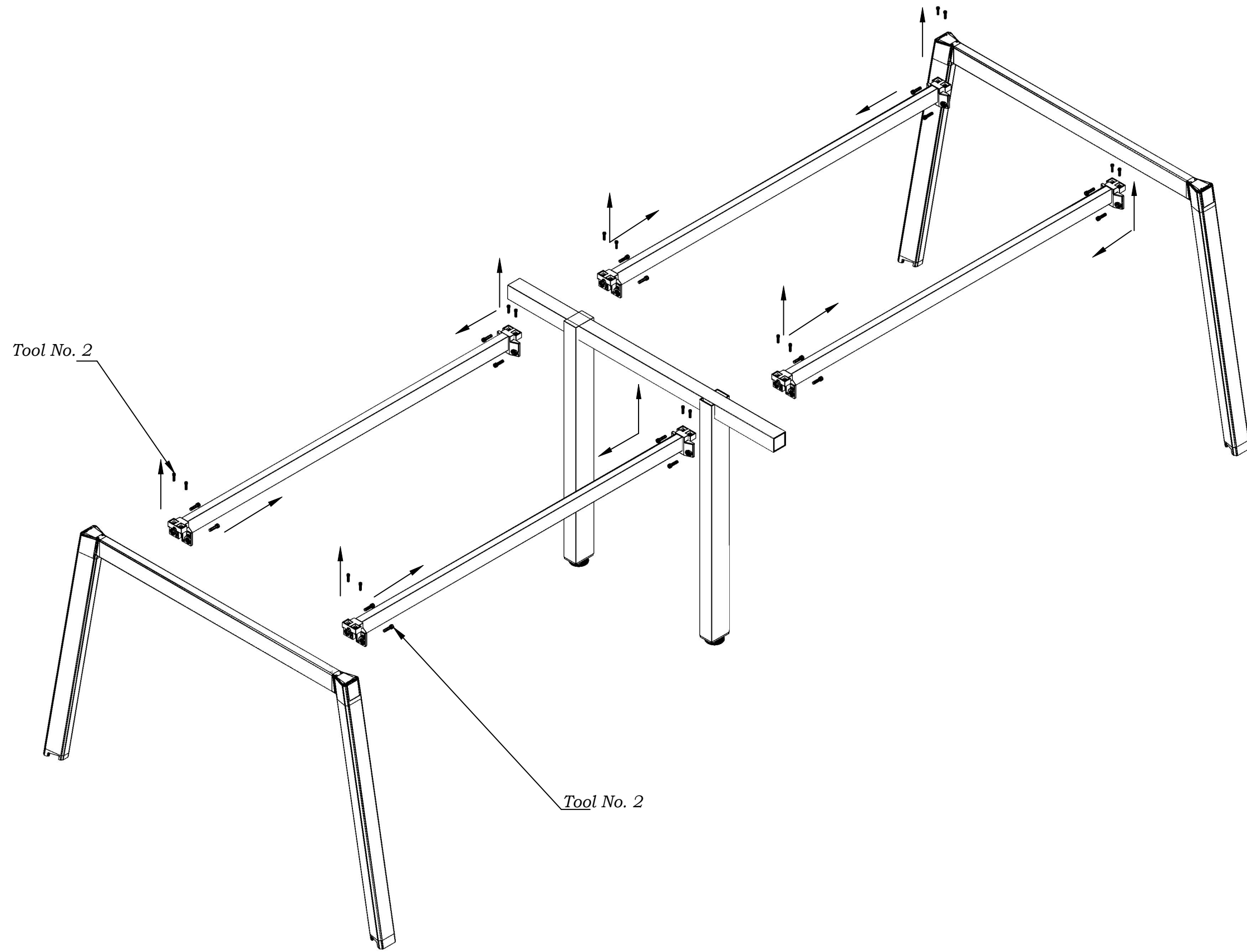
STEP 5 : RACEWAY/SIDE TRIM REMOVAL

Featherlite[®]



STEP 6 : CROSS BEAM & LEG ASSEMBLY REMOVAL

Featherlite[®]



Dis assembly instrcutions.

Disassembly Sequence, Time Schedule and Tools Requirement for SYNERGY Desking System.

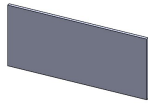
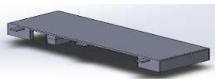
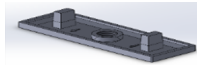
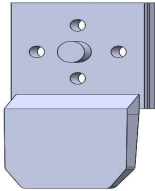
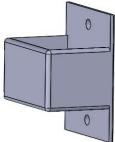

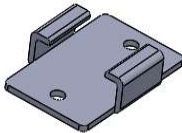
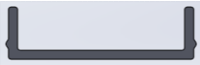


Table 1

<u>Sl.No</u>	<u>Activity</u>	<u>Time in min</u>	<u>Tools required</u>
1.	Disconnect sockets/switches and take out the cables.	4	Cordless Machine
2.	Remove the screens	3	Cordless Machine
3.	Remove Table Top	3	Cordless Machine
4.	Remove race way covers	2	Manual
5.	Remove the vertical wire management raceway.	3	Cordless Machine
6.	Remove Raceway frames.	3	Cordless Machine
7.	Remove cross beams	3	Allen Keys.
8.	Remove spacers.	2	Cordless Machine
9.	Remove leg supports.	2	Manual
10.	Remove accessories.	3	Cordless Machine
11.	Pack all components	4	Manual



Total time per work station- 32 Mins.

The timings are based on a cluster of 4 work stations. The dismantling team consists of two persons. For dismantling more number of work stations, larger team can be used and the activity can be telescoped.

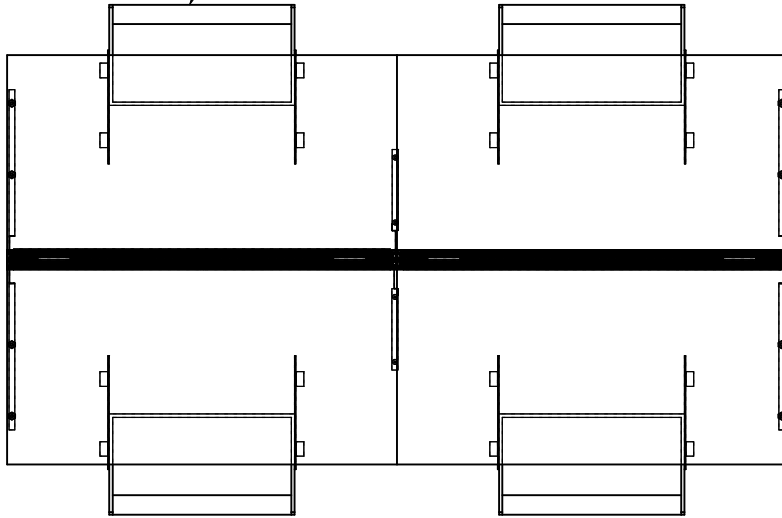
Components Used in AL60-30 Panel System

SL. No.	Components name	Images
1	Table Top	
2	Frame Top Caps	
3	Frame Bottom Caps	
4	Die Cast male Hooks	
5	Die Cast Female Hooks	
6	Sheetmetal Male Hook	
7	Sheetmetal Female hook	
8	Side Trim	
9	Leveller	
10	KeyBoard Tray	

TOOLS USED IN INSTALLATION

Tool No.	Name of the tool	Image
1	Cordless Machine	
2	Rubber Mallet	

Key Board Tray (4 No's)



60mm Frame (2 No's)

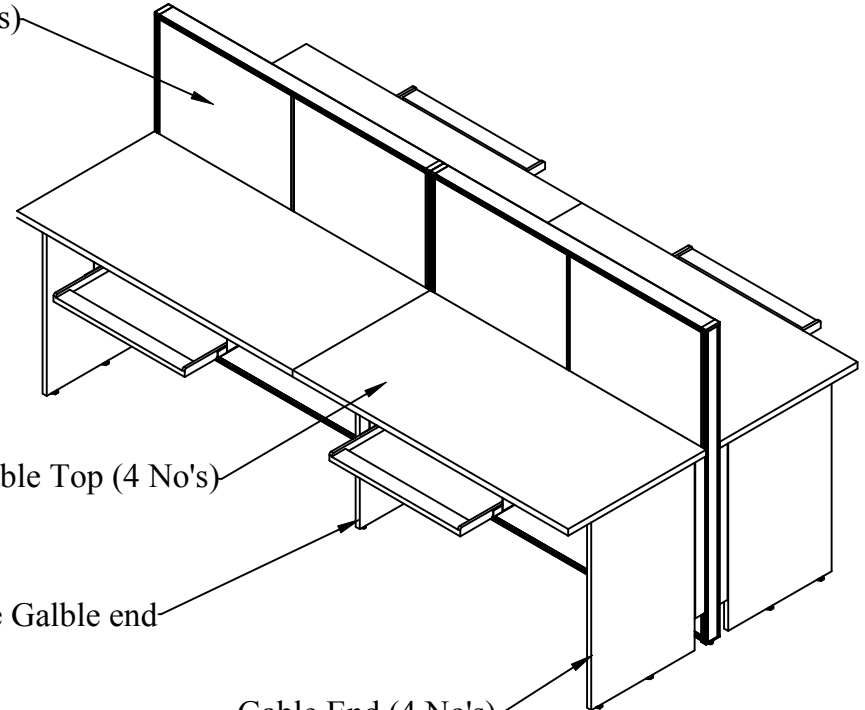


Table Top (4 No's)

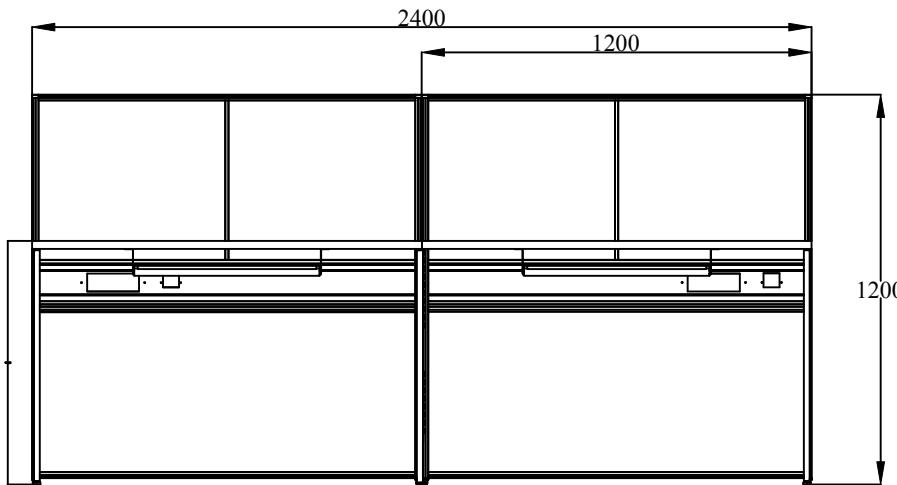
Intermediate Gable end

Gable End (4 No's)

2400

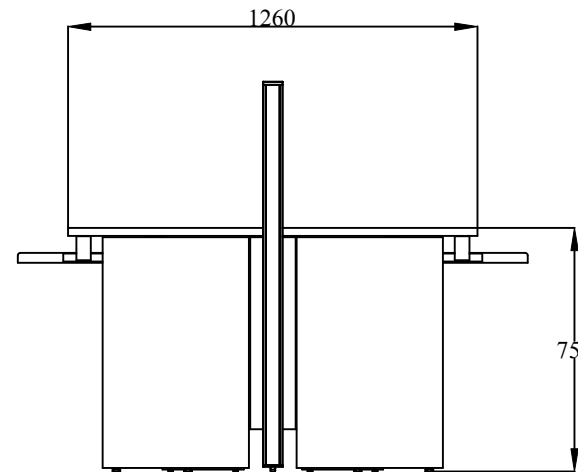
1200

1200



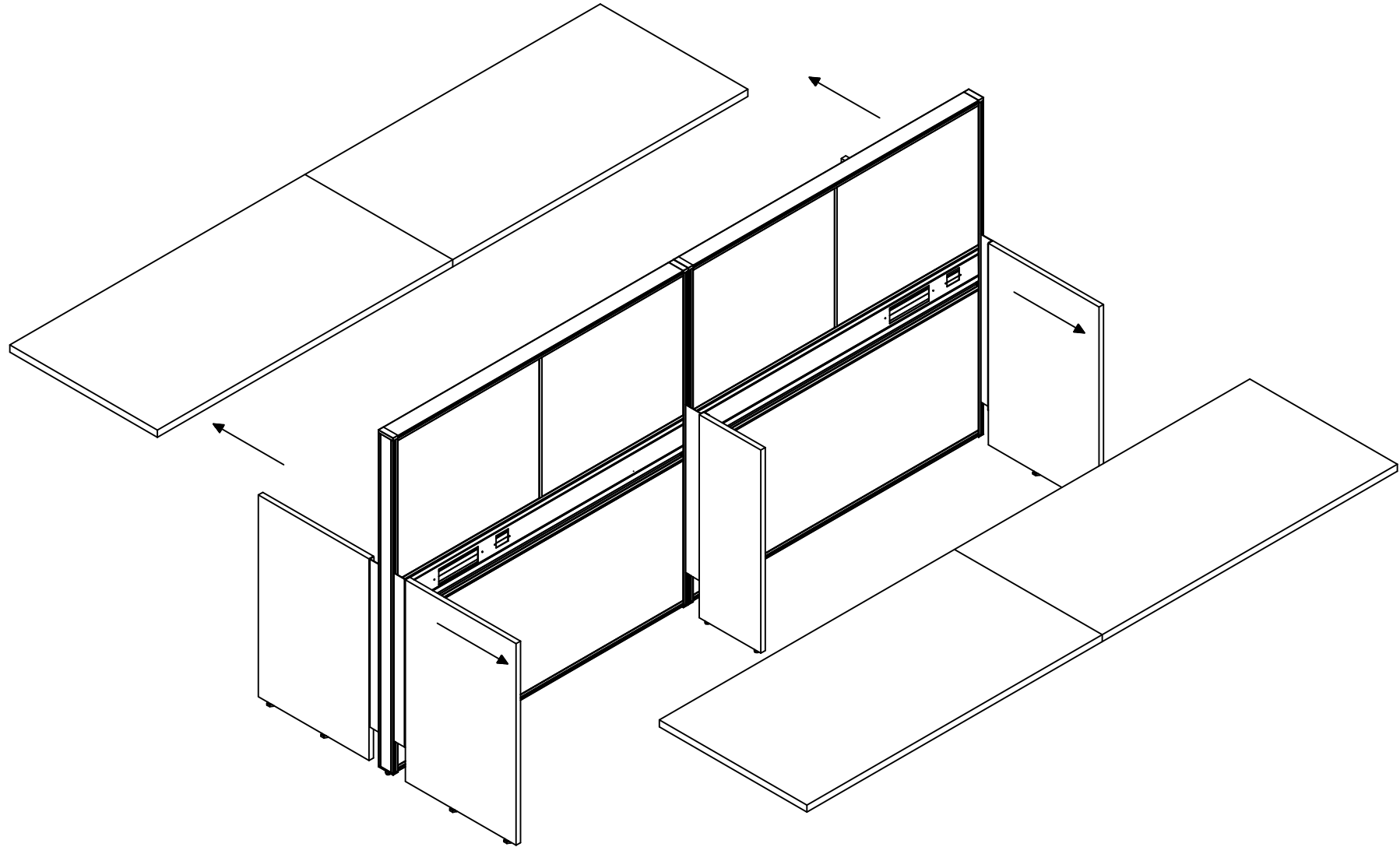
1260

750

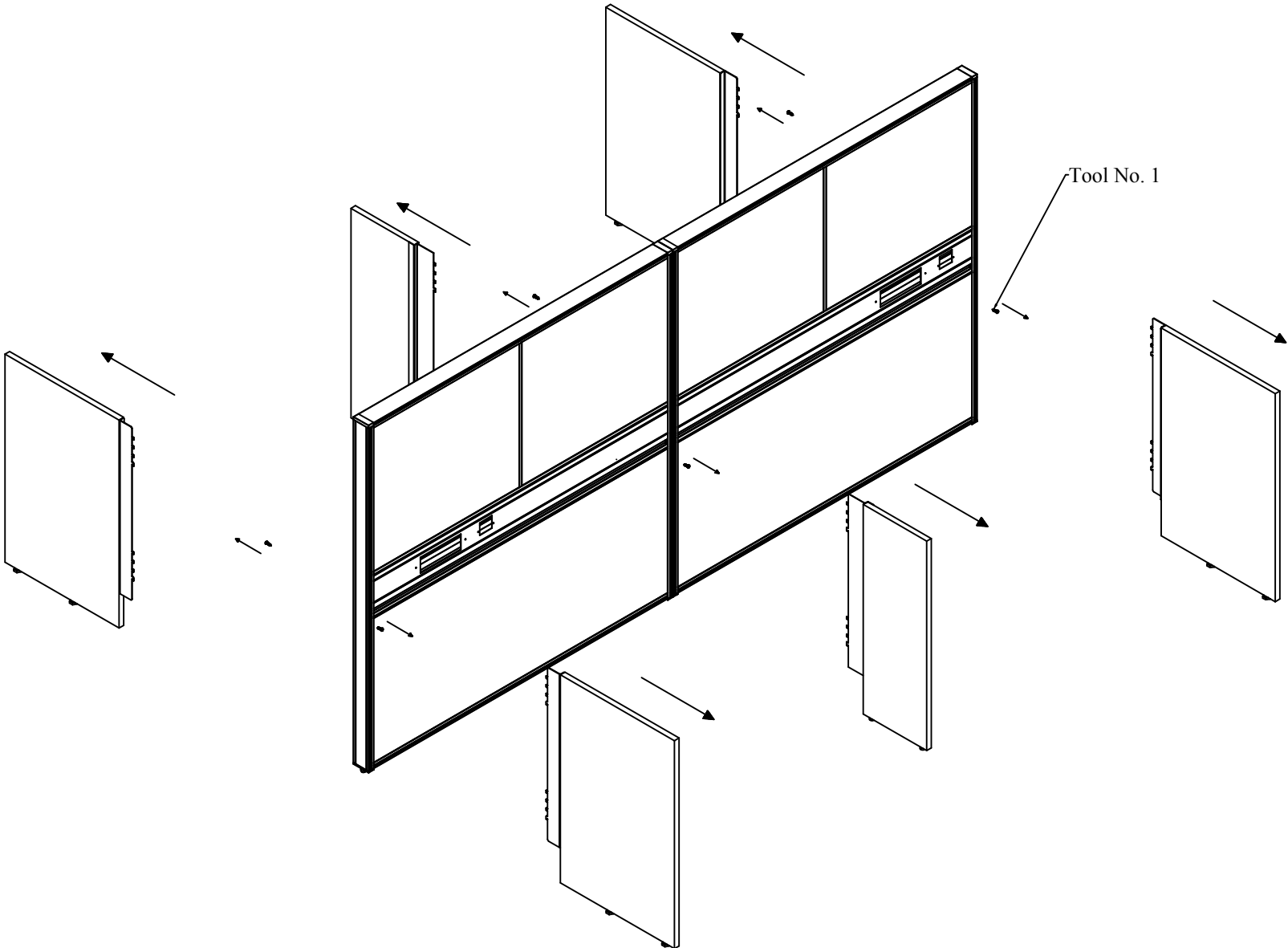


Step 1 :- Removing of Table Top.

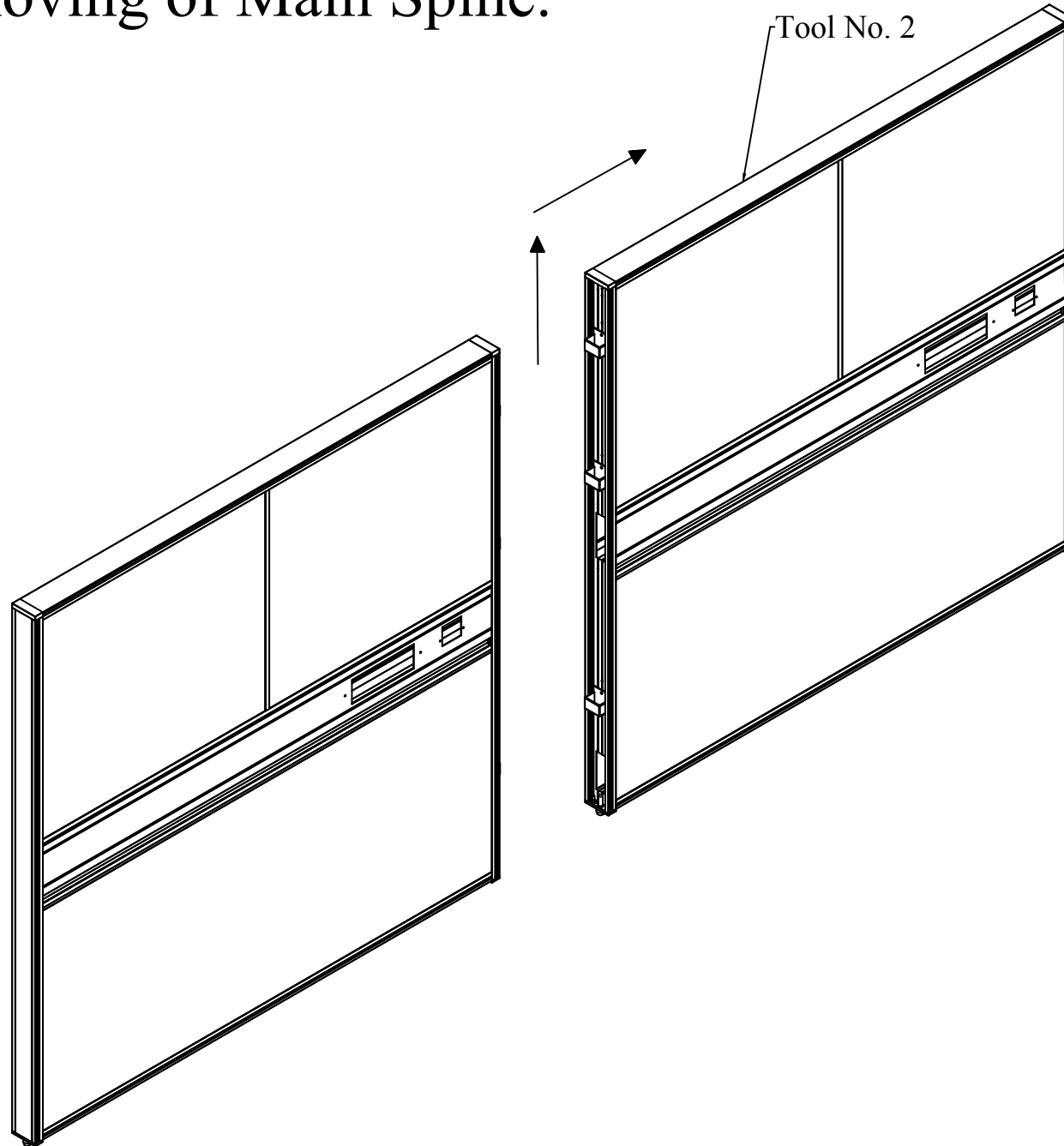
Featherlite[®]

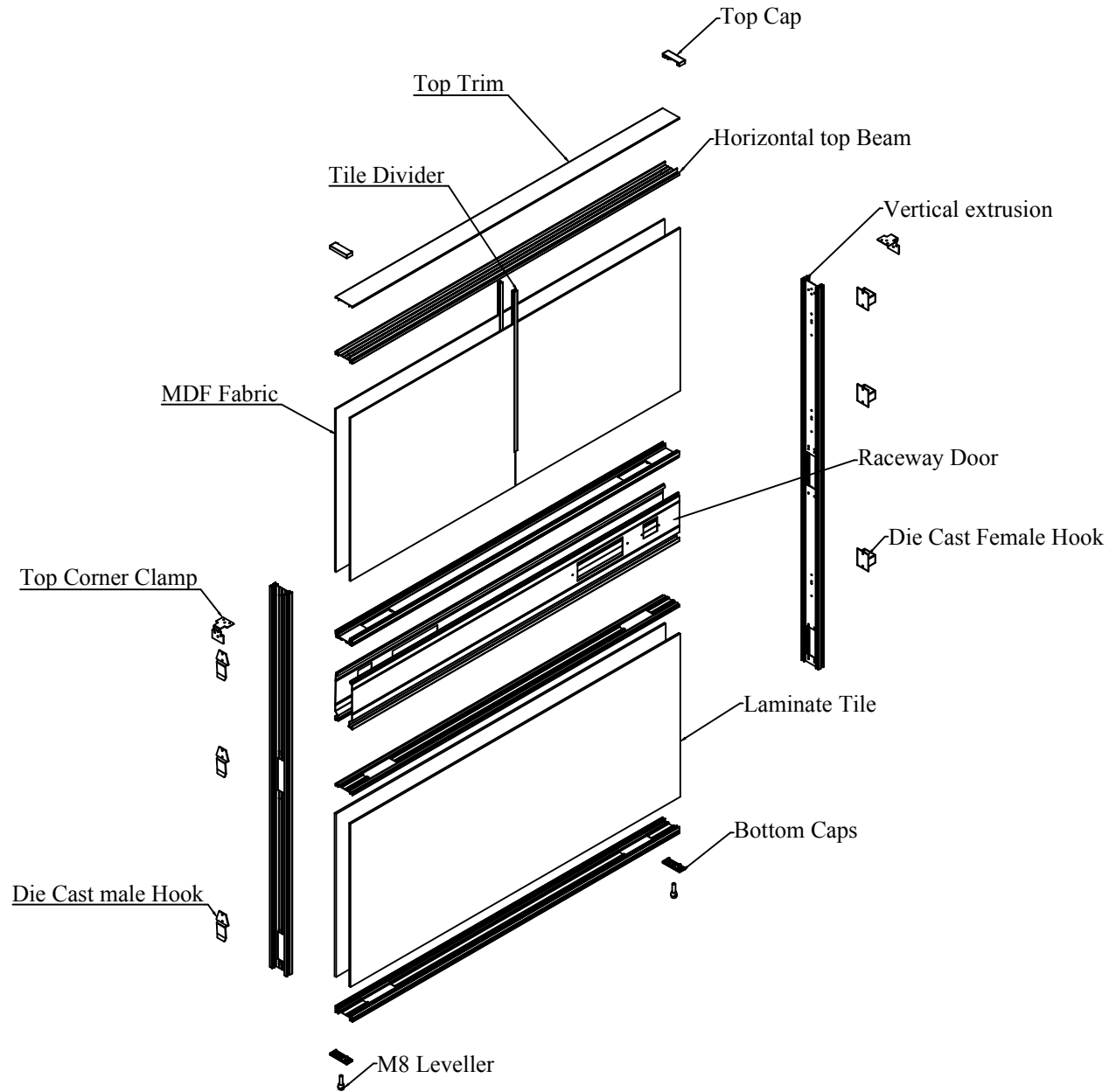


Step 2 :- Removing of gable ends.



Step 3 :- Removing of Main Spine.





Dis assembly instrcutions.

Disassembly Sequence, Time Schedule and Tools Requirement for AL 60/30 Panel system.

Table 1

<u>Sl.No</u>	<u>Activity</u>	<u>Time in min</u>	<u>Tools required</u>
1.	Disconnect sockets/switches and take out the cables.	4	Cordless machine
2.	Removal of Table Tops	3	Cordless machine
3.	Removal of Gabel Ends	3	Cordless machine
4.	Removal of main Spine frames	3	Manual
5.	Packing Of Materials.	2	Manual

Total time per work station- 15 Mins.

The timings are based on a cluster of 4 work stations. The dismantling team consists of two persons. For dismantling more number of work stations, larger team can be used and the activity can be telescoped.